

# Model ESFR-17 16.8 K-factor Pendent Sprinkler Early Suppression, Fast Response

## General Description

TYCO Model ESFR-17 Pendent Sprinklers are Early Suppression, Fast Response (ESFR) sprinklers having a nominal K-factor of 16.8 (Ref. Figures 1 and 2). They are suppression mode sprinklers that are especially advantageous as a means of eliminating in-rack sprinklers when protecting high-piled storage.

Model ESFR-17 Pendent Sprinklers are primarily used for ceiling-only sprinkler protection of (but not limited to) the following storage applications:

- most encapsulated or non-encapsulated common materials including cartoned, unexpanded plastics
- cartoned, expanded plastics
- uncartoned, unexpanded plastics
- uncartoned, expanded plastics
- some storage arrangements of rubber tires, roll paper, and aerosols

For more specific criteria, refer to Table 1 in this technical data sheet as well as the applicable design standard.

The Model ESFR-17 Pendent Sprinklers provide the system designer with hydraulic and sprinkler placement options not presently available to traditional ESFR Sprinklers having a nominal K-factor of 14.0. In particular, Model ESFR-17 Pendent Sprinklers are designed to operate at substantially lower-end head pressures, as

compared to ESFR Sprinklers having a nominal K-factor of 14.0. This feature offers flexibility when sizing system piping, as well as possibly reducing or eliminating the need for a system fire pump.

Applications for the ESFR-17 Pendent Sprinklers are expanding beyond currently recognized installation standards. For information on research fire tests (with flammable liquids and aerosols, for example) that may be acceptable to an authority having jurisdiction, contact Tyco Fire Protection Products (TFPP) Technical Services.

### NOTICE

*The Model ESFR-17 Pendent Sprinklers described herein must be installed and maintained in compliance with this document, as well as with the applicable standards of the National Fire Protection Association (NFPA), in addition to the standards of any authorities having jurisdiction (e.g., FM Global). Failure to do so may impair the performance of these devices.*

*The owner is responsible for maintaining their fire protection system and devices in proper operating condition. Contact the installing contractor or product manufacturer with any questions.*

*In all cases, the appropriate NFPA or FM Global installation standard, or other applicable standard, must be referenced to ensure applicability and to obtain complete installation guidelines. The general guidelines in this technical data sheet are not intended to provide complete installation criteria.*

## Sprinkler Identification Number (SIN)

TY7223

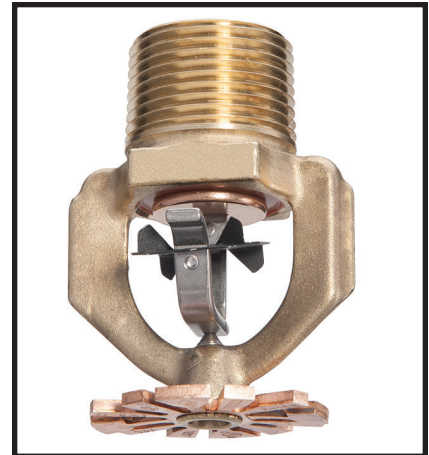

## Technical Data

**Approvals**  
UL Listed  
C-UL Listed  
FM Approved

**Maximum Working Pressure**  
175 psi (12,1 bar)

**Pipe Thread Connections**  
3/4 Inch NPT or ISO 7-R 3/4

**Discharge Coefficient**  
K=16.8 gpm/psi<sup>1/2</sup> (241,9 lpm/bar<sup>1/2</sup>)

**Temperature Ratings**  
165°F (74°C) and 212°F (100°C)

**Finish**  
Natural Brass

### Physical Characteristics

Frame .....	Brass
Deflector .....	Bronze
Compression Screw .....	Stainless Steel
Hook .....	MONEL
Strut .....	MONEL
Link Assembly .....	Solder, Nickel
Button .....	Phosphor Bronze
Sealing Assembly ..	Beryllium Nickel w/TEFLON

### IMPORTANT

*Always refer to Technical Data Sheet TFP700 for the "INSTALLER WARNING" that provides cautions with respect to handling and installation of sprinkler systems and components. Improper handling and installation can permanently damage a sprinkler system or its components and cause the sprinkler to fail to operate in a fire situation or cause it to operate prematurely.*

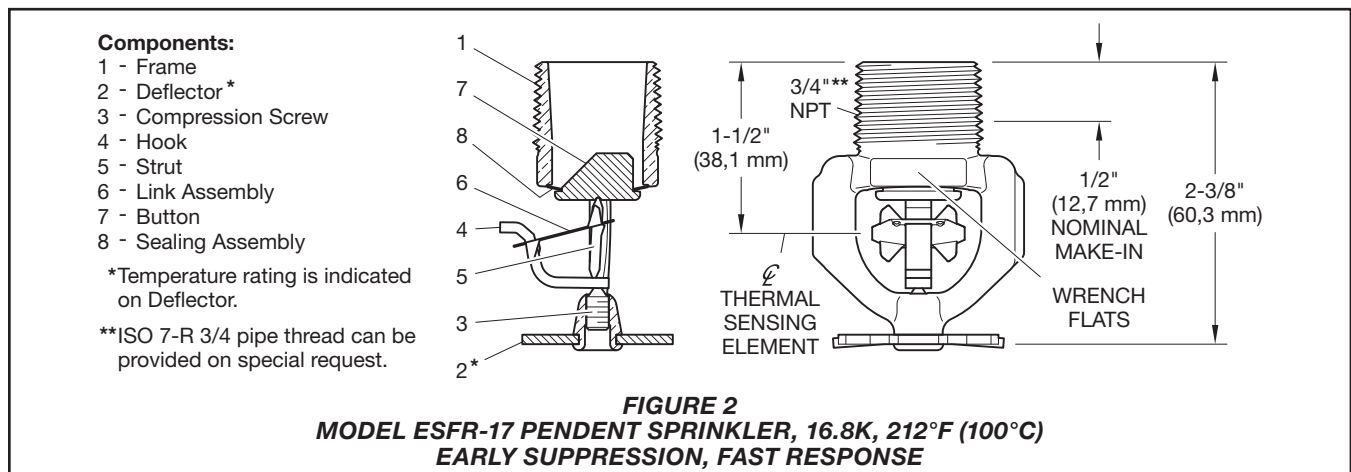
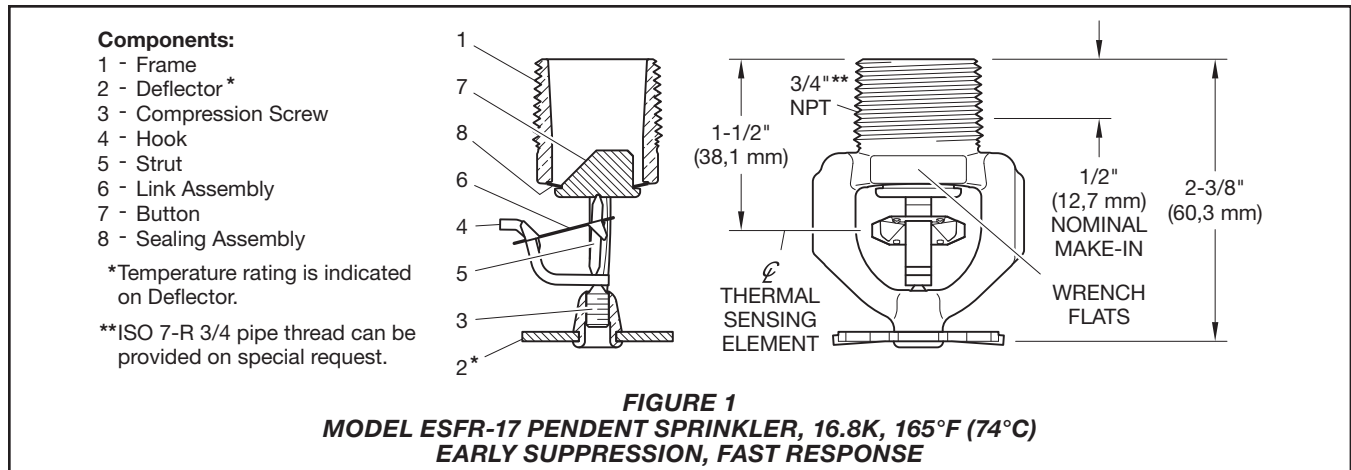

## Design Criteria

The following general guidelines provided for the TYCO Model ESFR-17 Pendent Sprinklers can be used for a quick reference.

The National Fire Protection Association (NFPA) and FM Global (FM Approvals) provide installation standards that must be used to properly design an automatic sprinkler system utilizing Early Suppression, Fast Response (ESFR) Sprinklers. The guidelines provided by NFPA and FM Global may differ. Consequently, the appropriate standard must be used for a given installation.

In all cases, the appropriate NFPA or FM Global installation standard must be referenced to ensure applicability and to obtain complete installation guidelines. The following general guidelines are not intended to provide complete installation criteria.

**System Type**  
 Wet Pipe

**Roof Construction**  
 Unobstructed or obstructed construction (e.g., smooth ceiling, bar joists, beam and girder, etc.).

Where the depths of the solid structural members (e.g., beams and stem) exceed 12 in. (302 mm), install ESFR Sprinklers in each channel formed by the structural members.

**Ceiling Slope**  
 Maximum 2 inch rise for 12 inch run (16.7%)

**Maximum Coverage Area**  
 100 ft.<sup>2</sup> (9,3 m<sup>2</sup>)

In some cases, the installation standards permit a greater coverage area.

**Minimum Coverage Area**  
 64 ft.<sup>2</sup> (5,8 m<sup>2</sup>) per NFPA 13

**Maximum Spacing**  
 12 feet (3,7 m) for building heights up to 30 feet (9,1 m)

10 feet (3,1 m) for building heights greater than 30 feet (9,1 m)

**Minimum Spacing**  
 8 feet (2,4 m)

**Minimum Clearance to Commodity**  
 36 inches (914 mm)

**NFPA 13**  
**Deflector-to-Ceiling Distance**  
 6 to 14 inches (152 to 356 mm)

**FM Global 2-0**  
 Consult FM Global and/or FM Global guidelines for allowable deflector-to-ceiling distances as well as thermal sensing element-to-ceiling criteria.

## Operation

The fusible link assembly is comprised of two link halves that are joined together by a thin layer of solder. When the rated temperature is reached, the solder melts and the two link halves separate, activating the sprinkler and flowing water.

Storage Type	NFPA
Open Frame (i.e., no solid shelves) Single, Double, Multiple-Row, or Portable Rack Storage of Class I-IV and Group A or B Plastics	Refer to NFPA 13 Chapters 16 & 17
Solid Pile or Palletized Storage of Class I-IV and Group A or B Plastics	Refer to NFPA 13 Chapters 14 & 15
Idle Pallet Storage	Refer to NFPA 13 Chapter 12
Rubber Tire Storage	Refer to NFPA 13 Chapter 18
Rolled Paper Storage (Refer to the standard)	Refer to NFPA 13 Chapter 19
Flammable Liquid Storage (Refer to the standard)	Refer to NFPA 30
Aerosol Storage (Refer to the standard)	Refer to NFPA 30B
Automotive Components in Portable Racks (Control mode only; refer to the standard)	N/A
N/A – Not Applicable	

**TABLE 1**  
**MODEL ESFR-17 PENDENT SPRINKLER**  
**COMMODITY SELECTION AND DESIGN CRITERIA OVERVIEW**

## Installation

TYCO Model ESFR-17 Early Suppression, Fast Response 16.8K Pendent Sprinklers must be installed in accordance with this section.

### General Instructions

Avoid damage to the fusible Link Assembly during installation by using only the Frame arms to handle the sprinkler (i.e., do not apply pressure to the fusible Link Assembly), and by using the appropriate sprinkler wrench. Failure to do so can lead to an unstable link assembly and premature activation of the sprinkler. Damaged sprinklers must be replaced.

A leak-tight 3/4 inch NPT sprinkler joint should be obtained by applying a minimum-to-maximum torque of 10 to 20 lbs.-ft. (13,4 to 26,8 Nm). Higher levels of torque can distort the sprinkler inlet with consequent leakage or impairment of the sprinkler.

**Note:** Install the Model ESFR-17 Pendent Sprinkler in the pendent position (Ref. Figures 3 and 4).

**Step 1.** With pipe-thread sealant applied, hand-tighten the sprinkler into the sprinkler fitting. Do not apply pressure to the Link Assembly, and handle the Model ESFR-17 Sprinkler only by the Frame arms.

**Step 2.** Wrench-tighten the Model ESFR-17 Sprinkler using only the W-Type 2 Sprinkler Wrench or the W-Type 30 Sprinkler Wrench (Ref. Figures 3 and 4), and by fully engaging (seating) the wrench on the sprinkler wrench flats (Ref. Figures 1 and 2).

**Step 3.** After installation, inspect the Link Assembly of each Model ESFR-17 Sprinkler for damage. In particular, verify that the Link Assembly and Hook are positioned as illustrated in Figures 1 and 2, and that the Link Assembly is not bent, creased, or forced out of normal position in any way. Replace damaged sprinklers.

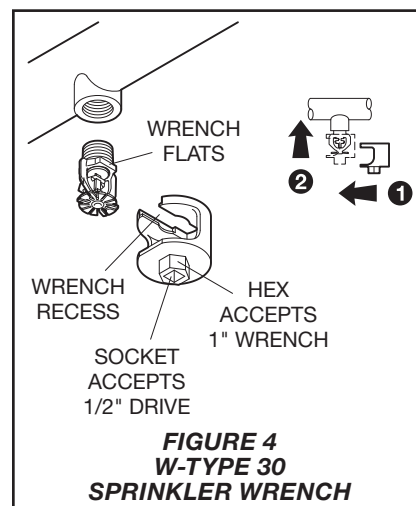
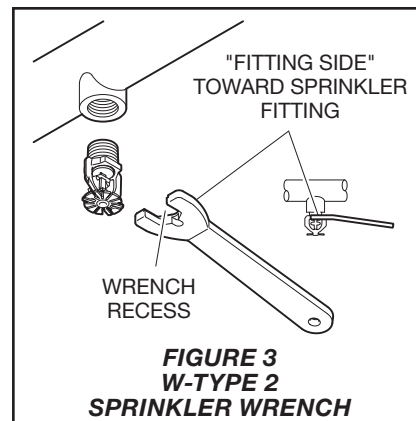

## Care and Maintenance

TYCO Model ESFR-17 Early Suppression, Fast Response 16.8K Pendent Sprinklers must be maintained and serviced in accordance with this section.

Before closing a fire protection system main control valve for maintenance work on the fire protection system that it controls, obtain permission to shut down the affected fire protection system from the proper authorities and notify all personnel who may be affected by this action.

Sprinklers which are found to be leaking or exhibiting visible signs of corrosion must be replaced.

Automatic sprinklers must never be painted, plated, coated, or otherwise altered after leaving the factory. Modified sprinklers must be replaced. Sprinklers that have been exposed to corrosive products of combustion, but have not operated, should be replaced if they cannot be completely cleaned by wiping the sprinkler with a cloth or by brushing it with a soft bristle brush.

Care must be exercised to avoid damage to the sprinklers before, during, and after installation. Sprinklers damaged by dropping, striking, wrench twist/slippage, or the like, must be replaced. Also, replace any sprinkler that has a cracked bulb or that has lost liquid from its bulb (Ref. Installation section).

The owner is responsible for the inspection, testing, and maintenance of their fire protection system and devices in compliance with this document, as well as with the applicable standards of the National Fire Protection Association (e.g., NFPA 25), in addition to the standards of any authorities having jurisdiction. Contact the installing contractor or product manufacturer with any questions.

Automatic sprinkler systems are recommended to be inspected, tested, and maintained by a qualified Inspection Service in accordance with local requirements and/or national codes.

## Limited Warranty

For warranty terms and conditions, visit [www.tyco-fire.com](http://www.tyco-fire.com).

## Ordering Procedure

Contact your local distributor for availability. When placing an order, indicate the full product name and part number (P/N).

### Sprinkler Assemblies with 3/4 NPT Thread Connection

Specify: Model ESFR-17 Early Suppression, Fast Response 16.8K Pendent Sprinklers (TY7223) with 3/4 NPT thread connection, (specify temperature rating), with Natural Brass finish, P/N (specify):

165°F (74°C) . . . . . P/N 58-455-1-165  
212°F (100°C) . . . . . P/N 58-455-1-214

### Special Order

#### Sprinkler Assemblies with ISO 7-R 3/4 Thread Connection

Specify: Model ESFR-17 Early Suppression, Fast Response 16.8K Pendent Sprinklers (TY7223) with ISO 7-R 3/4 thread connection, (specify temperature rating), with Natural Brass finish, P/N (specify):

165°F (74°C) . . . . . P/N 58-456-1-165  
212°F (100°C) . . . . . P/N 58-456-1-214

### Sprinkler Wrench

Specify: W-Type 2 Sprinkler Wrench, P/N 56-872-1-001

Specify: W-Type 30 Sprinkler Wrench, P/N 56-001-0-688