



Model EPEC — 115 K-factor Enhanced Protection Extended Coverage Pendent Sprinklers

General Description

The Model EPEC, 115 K-factor Enhanced Protection Extended Coverage Pendent Sprinklers described in this data sheet are intended to provide an alternate Ordinary Hazard Group III protection method when used as described in the LPC Rules for automatic sprinkler installations, TB222 — Ordinary Hazard Group III Protection Using Enhanced Extended Coverage Sprinklers. Except where modified by TB222, the system design and general protection methods shall be in accordance with LPC Rules for Automatic Sprinklers or BS EN 12845.

The principle objectives of the EPEC are to reduce the installed cost for a sprinkler system installation and to improve fire control performance characteristics as compared to traditional methods. The EPEC allows an increase in the maximum storage heights for Ordinary Hazard Group III, as well as for increased sprinkler coverage areas to 17,64 m² as compared to 12 m² for conventional and standard spray sprinklers. Increased design areas result in lower installation costs as a function of decreasing the number of branch lines and the associated piping materials.

The protection provided by the EPEC is based on extensive fire testing using Actual Delivered Density (ADD) and commodity fire tests. The effectiveness of the protection provided by

the EPEC is evidenced by its reduced water supply storage volume requirements (30 minutes versus 60 minutes).

NOTICE

The Model EPEC Enhanced Protection Extended Coverage Sprinklers described herein must be installed and maintained in compliance with this document, as well as with the applicable standards recognized by the Approval agency, in addition to the standards of any other authorities having jurisdiction. Failure to do so may impair the performance of these devices.

The owner is responsible for maintaining their fire protection system and devices in proper operating condition. The installing contractor or sprinkler manufacturer should be contacted with any questions.

Sprinkler Identification Number

TY4237

Technical Data

Approvals

LPCB (007N/01)

Maximum Working Pressure

12,1 bar

Pipe Thread Connection

3/4 NPT

Discharge Coefficient

K = 115 LPM/bar^{1/2}

Finish and Temperature Ratings

Refer to Table A.

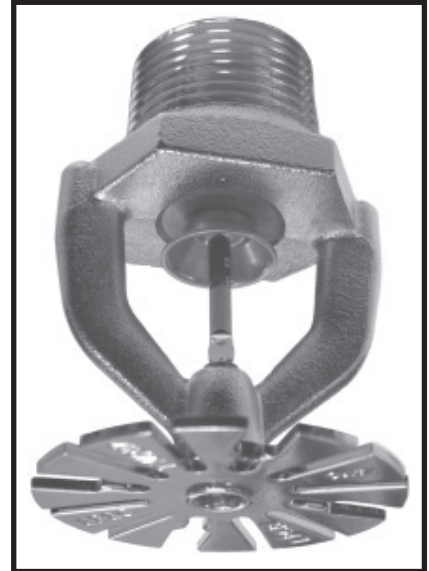

Physical Characteristics

Frame	Bronze
Button	Bronze/Copper
Sealing Assembly	Beryllium Nickel w/TEFLON
Bulb	Glass (3 mm dia.)
Compression Screw	Bronze
Deflector	Bronze

Operation

The glass bulb contains a fluid that expands when exposed to heat. When the rated temperature is reached, the fluid expands sufficiently to shatter the glass bulb, allowing the sprinkler to activate and flow water.

IMPORTANT

Always refer to Technical Data Sheet TFP700 for the "INSTALLER WARNING" that provides cautions with respect to handling and installation of sprinkler systems and components. Improper handling and installation can permanently damage a sprinkler system or its components and cause the sprinkler to fail to operate in a fire situation or cause it to operate prematurely.

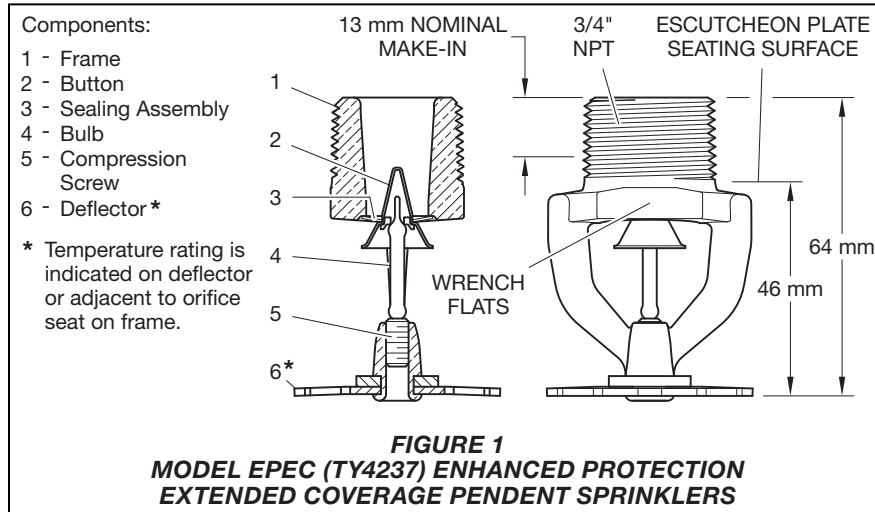

Design Criteria

The information provided in this section has been extracted from Technical Bulletin TB222 and, as provided, is intended to be used as a general guideline as to the applicability of the Model EPEC, 115 K-factor Enhanced Protection Extended Coverage Pendent Sprinklers.

NOTE: In all cases, Technical Bulletin TB222 must be referenced and followed to ensure an effective installation. The EPEC has significantly different water distribution characteristics from that of conventional and spray pattern sprinklers that has enabled the EPEC's use in conformance with Technical Bulletin TB222.

SYSTEM TYPE

Wet.

OCCUPANCY & FIRE HAZARD

- Ordinary Hazard Group III/10
- Ordinary Hazard Group III/12.5

The following conditions apply:

- The maximum storage heights specified in Table B shall not be exceeded.
- The maximum storage area shall not exceed 100 m² for any single block with less than 1,5 m clearance around the block.
- The maximum ceiling height shall not exceed 5,5 m.
- The ceiling slope shall not exceed 9° (170 mm/m).
- Containers with an open end facing up shall not be stored in the protected areas. (Containers with the open end facing down are acceptable.)

- No process occupancies classified as Ordinary Hazard Group III Special shall be within the protected areas.

DESIGN

- OHIII/10

Minimum pressure:

1,9 bar for 4 sprinklers for coverage areas less than or equal to 16 m²/sprinkler.

2,3 bar for 4 sprinklers for coverage areas greater than 16 m²/sprinkler up to and equal to 17,64 m²/sprinkler.

Minimum density:

6.0 mm/min over 160 m².

- OHIII/12.5

Minimum pressure:

3,0 bar for 4 sprinklers for coverage areas less than or equal to 16 m²/sprinkler.

3,6 bar for 4 sprinklers for coverage areas greater than 16 m²/sprinkler up to and equal to 17,64 m²/sprinkler.

Minimum density:

6.5 mm/min over 160 m².

WATER SUPPLY DURATION

Minimum 30 minutes.

SPRINKLER LOCATION & SPACING

- Clearance between deflector and top of storage: 1 m.
- Maximum area of coverage per sprinkler: 17,64 m².
- Maximum spacing of sprinklers — standard layout: 4,2 m across or along ranges.
- Maximum spacing of sprinklers — staggered layout: 4,2 m across ranges and 4,6 m along ranges.

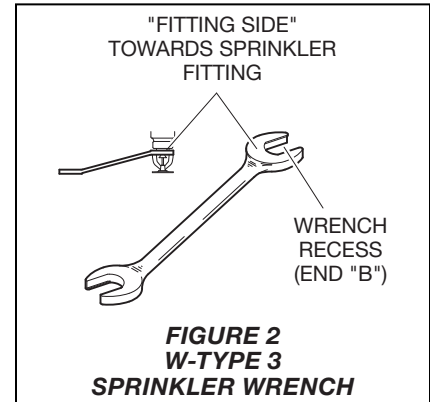

- Minimum spacing of sprinklers: 2,0 m unless provisions are made to prevent cold soldering.
- Maximum distance from walls and partitions shall be 2,1 m for standard spacing; 2,3 m for staggered spacing; or, 1,5 m where the external walls are combustible or are metal, with or without combustible linings or insulating materials.
- Sprinkler deflector to ceiling/roof distance shall be 30 mm to 150 mm.

LIMITATIONS OF USE

The protection provided by EPEC Sprinklers should not be used where one of the following may be present:

- Materials in which fires cannot readily be controlled by sprinklers (example: acrylic fiber yarn storage).
- Commodities or storage arrangements that give rise to unusually severe fire characteristics (example: lightweight paper storage).
- Open top storage containers (example: open top tote boxes).
- Ceilings with joists, deep beams, or significant obstructions.

Installation

The Model EPEC, 115 K-factor Enhanced Protection Extended Coverage Pendent Sprinklers must be installed in accordance with this section.

General Instructions

Do not install any bulb type sprinkler if the bulb is cracked or there is a loss of liquid from the bulb. With the sprinkler held horizontally, a small air bubble should be present. The diameter of the air bubble is approximately 1,6 mm.

A leak tight 3/4 inch NPT sprinkler joint should be obtained with a torque of 13,4 to 26,8 Nm. A maximum of 40,7 Nm of torque is to be used to install sprinklers. Higher levels of torque

HAZARD	TYPE	TEMP.	BULB LIQUID COLOR	SPRINKLER FINISH		
				NATURAL BRASS	CHROME PLATED	PURE* WHITE (RAL9010)
ORDINARY GROUP III/10 OR III/12.5 As defined in Technical Bulletin 222	EPEC Pendent	57°C	Orange	Approved by the Loss Prevention Certification Board (LPCB)		
		68°C	Red			
		79°C	Yellow			
		93°C	Green			
		141°C	Blue			
*Frame and Deflector only.						
TABLE A LABORATORY APPROVALS <i>(Refer to the Design Criteria Section)</i>						

STORAGE CATEGORY	MAXIMUM STORAGE HEIGHT, m			
	ORDINARY HAZARD III/10		ORDINARY HAZARD III/12.5	
	Free Standing or Block Stacking (Note 1)	All Other Storage Methods (Note 2)	Free Standing or Block Stacking (Note 1 & 3)	All Other Storage Methods (Note 2 & 3)
I	4,0	3,5	4,5	4,0
II	3,0	2,6	4,0	3,5
III	2,1	1,7	3,1	2,6
IV (Note 4)	1,2	1,2	1,5	1,5
NOTES: 1. Free standing and block stacking ST1 only. 2. All other storage methods ST2 to ST6. 3. Storage areas to the heights specified shall not exceed 4 m ² in plan area. See TB222.3.2. 4. Not including exposed expanded plastic.				
TABLE B MAXIMUM STORAGE HEIGHTS				

may distort the sprinkler inlet with consequent leakage or impairment of the sprinkler.

Do not attempt to compensate for insufficient adjustment of an Escutcheon Plate by under-or over-tightening the Sprinkler. Re-adjust the position of the sprinkler fitting to suit.

Step 1. The sprinkler must be installed with the deflector parallel to the mounting surface. Pendent sprinklers must be installed in the pendent position.

Step 2. After installing an escutcheon, as applicable, over the sprinkler pipe threads, and with pipe thread sealant applied to the pipe threads, hand tighten the sprinkler into the sprinkler fitting.

Step 3. Wrench tighten pendent sprinklers using only the W-Type 3 (End B) Sprinkler Wrench. The wrench recess of the sprinkler wrench (Ref. Figure 2) is to be applied to the sprinkler wrench flats (Ref. Figure 1).

Care and Maintenance

The Model EPEC, 115 K-factor Enhanced Protection Extended Coverage Pendent Sprinklers must be maintained and serviced in accordance with this section

Before closing a fire protection system main control valve for maintenance work on the fire protection system that it controls, permission to shut down the affected fire protection systems must be obtained from the proper authorities and all personnel who may be affected by this action must be notified.

Sprinklers that are found to be leaking or exhibiting visible signs of corrosion must be replaced.

Automatic sprinklers must never be painted, plated, coated, or otherwise altered after leaving the factory. Modified sprinklers must be replaced. Sprinklers that have been exposed to corrosive products of combustion, but have not operated, should be replaced if they cannot be completely cleaned

by wiping the sprinkler with a cloth or by brushing it with a soft bristle brush.

Care must be exercised to avoid damage to the sprinklers -before, during, and after installation. Sprinklers damaged by dropping, striking, wrench twist/slippage, or the like, must be replaced. Also, replace any sprinkler that has a cracked bulb or that has lost liquid from its bulb. (Ref. Installation Section).

The owner is responsible for the inspection, testing, and maintenance of their fire protection system and devices in compliance with this document, as well as with the applicable standards of the authorities having jurisdiction. The installing contractor or sprinkler manufacturer should be contacted relative to any questions.

It is recommended that automatic sprinkler systems be inspected, tested, and maintained by a qualified Inspection Service in accordance with local requirements and/or national codes.

Ordering Procedure

Contact your local distributor for availability. When placing an order, indicate the full product name and Part Number (P/N).

Sprinkler Assemblies:

Specify: Model EPEC (TY4237), Enhanced Protection Extended Coverage Pendent Sprinkler (specify) temperature rating, with (specify) finish, P/N (specify).

57°C

Natural Brass PSN 55-101-1-135
Pure White (RAL9010) . PSN 55-101-3-135
Chrome Plated PSN 55-101-9-135

68°C

Natural Brass PSN 55-101-1-155
Pure White (RAL9010) . PSN 55-101-3-155
Chrome Plated PSN 55-101-9-155

79°C

Natural Brass PSN 55-101-1-175
Pure White (RAL9010) . PSN 55-101-3-175
Chrome Plated PSN 55-101-9-175

93°C

Natural Brass PSN 55-101-1-200
Pure White (RAL9010) . PSN 55-101-3-200
Chrome Plated PSN 55-101-9-200

141°C

Natural Brass PSN 55-101-1-286
Pure White (RAL9010) . PSN 55-101-3-286
Chrome Plated PSN 55-101-9-286

Sprinkler Wrench:

Specify: W-Type 3 Sprinkler Wrench, P/N 56-895-1-001