

## **RAPID RESPONSE Series LFII Residential 4.9 K-factor Concealed Pendent Sprinkler Flat Plate, Wet Pipe and Dry Pipe Systems**

### **General Description**

TYCO RAPID RESPONSE Series LFII Residential 4.9K Concealed Pendent Sprinklers (TY3596) are decorative, fast response, fusible solder sprinklers designed for use in residential occupancies such as homes, apartments, dormitories, and hotels.

The cover plate assembly conceals the sprinkler operating components above the ceiling. The flat profile of the cover plate provides the optimum aesthetically appealing sprinkler design. In addition, the concealed design of the Series LFII Residential Concealed Pendent Sprinklers (TY3596) provides 1/2 inch (12,7 mm) vertical adjustment. This adjustment provides a measure of flexibility when cutting fixed sprinkler drops.

The Series LFII Residential Concealed Sprinklers are intended for use in the following scenarios:

- wet and dry pipe residential sprinkler systems for one- and two-family dwellings and mobile homes per NFPA 13D
- wet and dry pipe residential sprinkler systems for residential occupancies up to and including four stories in height per NFPA 13R
- wet and dry pipe sprinkler systems for the residential portions of any occupancy per NFPA 13

#### **IMPORTANT**

*Always refer to Technical Data Sheet TFP700 for the "INSTALLER WARNING" that provides cautions with respect to handling and installation of sprinkler systems and components. Improper handling and installation can permanently damage a sprinkler system or its components and cause the sprinkler to fail to operate in a fire situation or cause it to operate prematurely.*

The Series LFII Residential Concealed Pendent Sprinklers (TY3596) has been designed with heat sensitivity and water distribution characteristics proven to help in the control of residential fires and to improve the chance for occupants to escape or be evacuated.

The Series LFII Residential Concealed Pendent Sprinklers (TY3596) are shipped with a Disposable Protective Cap. The Protective Cap is temporarily removed for installation, and then it can be replaced to help protect the sprinkler while the ceiling is being installed or finished. The tip of the Protective Cap can also be used to mark the center of the ceiling hole into plaster board, ceiling tiles, etc. by gently pushing the ceiling product against the Protective Cap. When the ceiling installation is complete the Protective Cap is removed and the Cover Plate Assembly installed.

#### **Dry Pipe System Application**

The Series LFII Residential Concealed Pendent Sprinklers offers a laboratory approved option for designing dry pipe residential sprinkler systems, whereas, most residential sprinklers are laboratory approved for wet systems only.

Through extensive testing, it has been determined that the number of design sprinklers (hydraulic design area) for the Series LFII Residential Concealed Pendent Sprinklers (TY3596) need not be increased over the number of design sprinklers (hydraulic design area) as specified for wet pipe sprinkler systems, as is accustomed for density/area sprinkler systems designed per NFPA 13.

Consequently, the Series LFII Residential Concealed Pendent Sprinklers offer the features of non-water filled pipe in addition to not having to increase the number of design sprinklers (hydraulic design area) for systems designed to NFPA 13, 13D, or 13R.



#### **NOTICE**

*The Series LFII Residential Concealed Pendent Sprinklers (TY3596) described herein must be installed and maintained in compliance with this document and with the applicable standards of the National Fire Protection Association (NFPA), in addition to the standards of any authorities having jurisdiction. Failure to do so may impair the performance of these devices.*

*The owner is responsible for maintaining their fire protection system and devices in proper operating condition. Contact the installing contractor or product manufacturer with any questions.*

### **Sprinkler Identification Number (SIN)**

TY3596

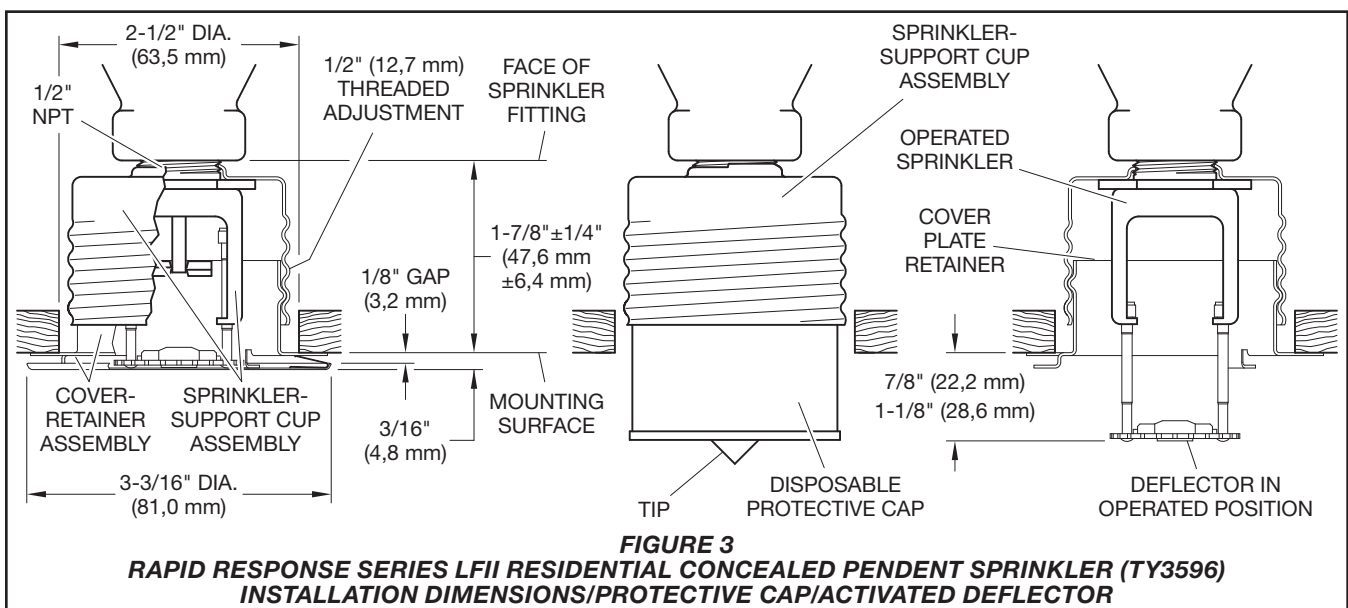
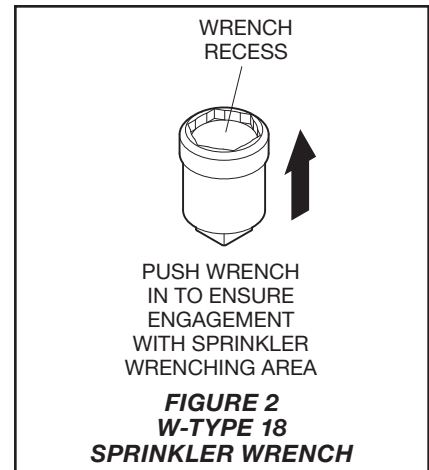
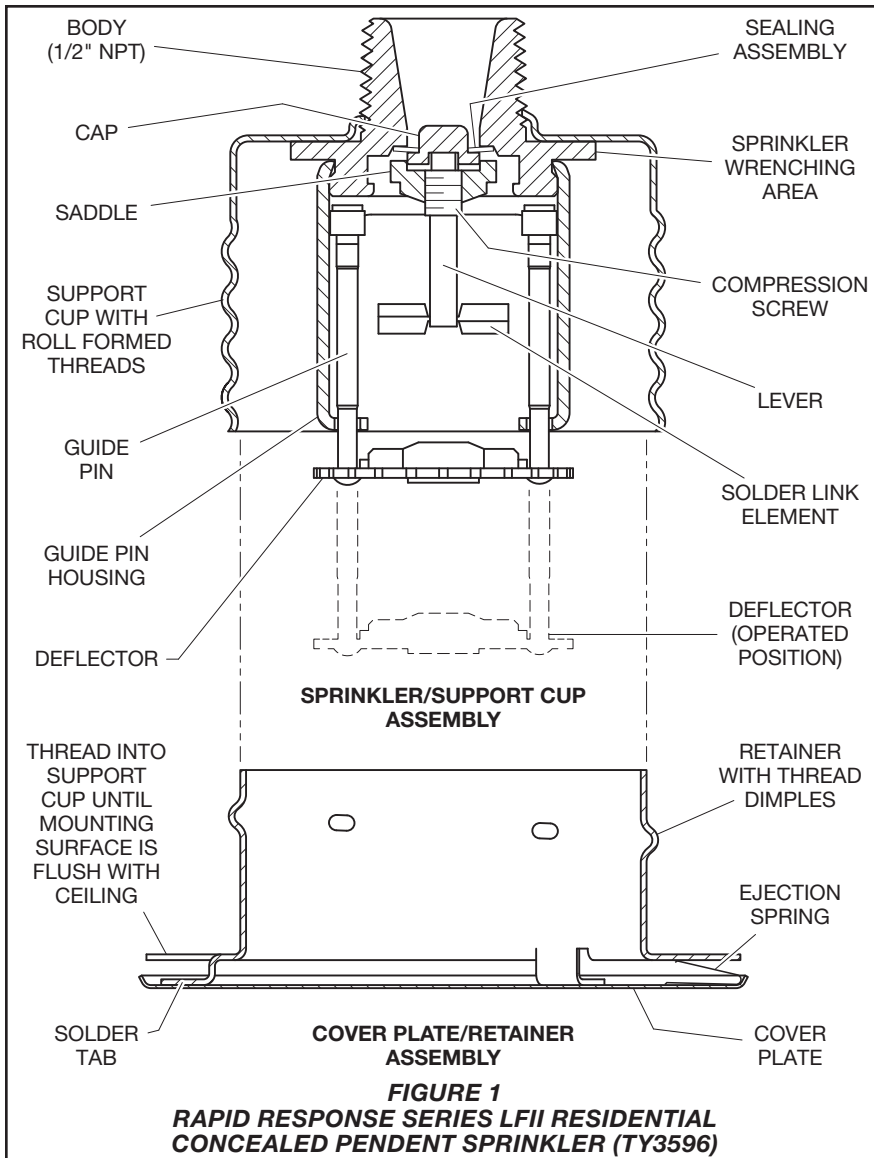

## Technical Data

### Approvals

UL and C-UL Listed  
NYC Approved under MEA 44-03-E-2NSF  
Certified to NSF/ANSI 61

The TYCO RAPID RESPONSE Series LFII Residential Concealed Pendent Sprinklers are only Listed with the Series LFII Concealed Cover Plates having a factory-applied finish.

Cover Plates can be ordered by following the instructions in the Ordering Procedure section.

### Maximum Working Pressure

175 psi (12,1 bar)

### Discharge Coefficient

$K=4.9 \text{ gpm/psi}^{1/2}$  (70,6 lpm/bar<sup>1/2</sup>)

### Temperature Rating

160°F (71°C) Sprinkler with  
139°F (59°C) Cover Plate

### Vertical Adjustment

1/2 inch (12,7 mm)

### Finishes

Refer to Ordering Procedure section.

### Physical Characteristics

Body	Brass
Cap	Bronze
Saddle	Brass
Sealing Assembly	Beryllium Nickel w/TEFLON
Soldered Link Halves	Nickel
Lever	Bronze
Compression Screw	Brass
Deflector	Copper or Brass
Guide Pin Housing	Bronze
Guide Pins	Stainless Steel or Bronze
Support Cup	Steel
Cover Plate	Copper
Retainer	Brass
Cover Plate	
Ejection Spring	Stainless Steel

## Operation

When exposed to heat from a fire, the Cover Plate, which is normally soldered to the Support Cup at three points, falls away to expose the sprinkler assembly. At this point the Deflector supported by the Arms drops down to its operated position. The fusible link of the sprinkler assembly is comprised of two link halves that are soldered together with a thin layer of solder. When the rated temperature is reached, the solder melts and the two link halves separate allowing the sprinkler to activate and flow water.

## Design Criteria

TYCO RAPID RESPONSE Series LFII Residential Concealed Pendent Sprinklers (TY3596) are UL and C-UL Listed for installation in accordance with this section.

**Note:** When conditions exist that are outside the scope of the provided criteria, refer to the Residential Sprinkler Design Guide TFP490 for the manufacturer's recommendations that may be acceptable to the authority having jurisdiction.

### System Types

Per the UL Listing, wet pipe and dry pipe systems may be utilized. Per the C-UL Listing, only wet pipe systems may be utilized.

Refer to Technical Data Sheet TFP485 about the use of residential sprinklers in residential dry pipe systems.

### Ceiling Types

Smooth flat horizontal, or beamed, or sloped, in accordance with the 2013 Edition of NFPA 13D, 13R, or 13 as applicable.

### Hydraulic Design

#### (NFPA 13D and 13R)

For systems designed to NFPA 13D or NFPA 13R, the minimum required sprinkler flow rates are given in Tables A and B as a function of temperature rating and the maximum allowable coverage areas. The sprinkler flow rate is the minimum required discharge from each of the total number of "design sprinklers" as specified in NFPA 13D or NFPA 13R. The number of "design sprinklers" specified in NFPA 13D and 13R for wet pipe systems is to be applied when designing dry pipe systems.

### Hydraulic Design

#### (NFPA 13)

For systems designed to NFPA 13, the number of design sprinklers is to be the four most hydraulically demanding sprinklers. The minimum required discharge from each of the four sprinklers is to be the greater of the following:

- the flow rates given in Tables A and B as a function of temperature rating and the maximum allowable coverage area
- a minimum discharge of 0.1 gpm/ft.<sup>2</sup> over the design area comprised of the four (4) most hydraulically demanding sprinklers for actual coverage areas protected by the four (4) sprinklers

The number of design sprinklers specified in NFPA 13 for wet pipe systems is to be applied when designing dry pipe systems.

### Dry Pipe System Water Delivery

When using the Series LFII Residential Concealed Pendent Sprinklers (TY3596) in dry pipe sprinkler systems, the time for water delivery must not exceed 15 seconds for the most remote operating sprinkler.

### Obstruction to

#### Water Distribution

Sprinklers are to be located in accordance with the obstruction rules of NFPA 13D, 13R, and 13 as applicable for residential sprinklers as well as with the obstruction criteria described within the Technical Data Sheet TFP490.

### Operational Sensitivity

The sprinklers are to be installed relative to the ceiling mounting surface as shown in Figure 3.

### Sprinkler Spacing

The minimum spacing between sprinklers is 8 feet (2,4 m). The maximum spacing between sprinklers cannot exceed the length of the coverage area (Ref. Table A or B) being hydraulically calculated (e.g., maximum 12 feet for a 12 ft. x 12 ft. coverage area, or 20 feet for a 20 ft. x 20 ft. coverage area).

The Series LFII must not be used in applications where the air pressure above the ceiling is greater than that below. Down drafts through the Support Cup could delay sprinkler operation in a fire situation.

Maximum Coverage Area <sup>1</sup> Ft. x Ft. (m x m)	Maximum Spacing Ft. (m)	WET PIPE SYSTEM Minimum Flow and Residual Pressure <sup>2,3</sup>				
		Ordinary Temp. Rating 160°F (71°C)		Deflector to Ceiling	Installation Type	Minimum Spacing Ft. (m)
		Flow gpm (lpm)	Pressure psi (bar)			
12 x 12 (3,7 x 3,7)	12 (3,7)	13 (49,2)	7.0 (0,48)	Smooth Ceilings 7/8 to 1-1/8 inches  Beamed Ceilings per NFPA 13D or 13R, or 13. Installed in beam 7/8 to 1-1/8 inches below bottom of beam	Concealed	8 (2,4)
14 x 14 (4,3 x 4,3)	14 (4,3)	13 (49,2)	7.0 (0,48)			
16 x 16 (4,9 x 4,9)	16 (4,9)	13 (49,2)	7.0 (0,48)			
18 x 18 (5,5 x 5,5)	18 (5,5)	17 (64,3)	12.0 (0,83)			
20 x 20 (6,1 x 6,1)	20 (6,1)	20 (75,7)	16.7 (1,15)			

**Notes:**

- For coverage area dimensions less than or between those indicated, use the minimum required flow for the next highest coverage area for which hydraulic design criteria are stated.
- Requirement is based on minimum flow in gpm (lpm) from each sprinkler. The associated residual pressures are calculated using the nominal K-factor. Refer to Hydraulic Design under the Design Criteria section.
- For NFPA 13 residential applications, the greater of 0.1 gpm/ft.<sup>2</sup> over the design area or the flow in accordance with the criteria in this table must be used.

**TABLE A**  
**WET PIPE SYSTEM**  
**SERIES LFII RESIDENTIAL 4.9 K-FACTOR FLAT PLATE CONCEALED PENDENT SPRINKLER (TY3596)**  
**NFPA 13D, 13R, AND 13 HYDRAULIC DESIGN CRITERIA**

Maximum Coverage Area <sup>1</sup> Ft. x Ft. (m x m)	Maximum Spacing Ft. (m)	DRY PIPE SYSTEM Minimum Flow and Residual Pressure <sup>2,3</sup>				
		Ordinary Temp. Rating 160°F (71°C)		Deflector to Ceiling	Installation Type	Minimum Spacing Ft. (m)
		Flow gpm (lpm)	Pressure psi (bar)			
12 x 12 (3,7 x 3,7)	12 (3,7)	13 (49,2)	7.0 (0,48)	Smooth Ceilings 7/8 to 1-1/8 inches  Beamed Ceilings per NFPA 13D or 13R, or 13. Installed in beam 7/8 to 1-1/8 inches below bottom of beam	Concealed	8 (2,4)
14 x 14 (4,3 x 4,3)	14 (4,3)	14 (53,0)	8.2 (0,57)			
16 x 16 (4,9 x 4,9)	16 (4,9)	15 (56,8)	9.4 (0,65)			
18 x 18 (5,5 x 5,5)	18 (5,5)	18 (68,1)	13.5 (0,93)			
20 x 20 (6,1 x 6,1)	20 (6,1)	21 (79,5)	18.4 (1,27)			

**Notes:**

- For coverage area dimensions less than or between those indicated, use the minimum required flow for the next highest coverage area for which hydraulic design criteria are stated.
- Requirement is based on minimum flow in gpm (lpm) from each sprinkler. The associated residual pressures are calculated using the nominal K-factor. Refer to Hydraulic Design under the Design Criteria section.
- For NFPA 13 residential applications, the greater of 0.1 gpm/ft.<sup>2</sup> over the design area or the flow in accordance with the criteria in this table must be used.

**TABLE B**  
**DRY PIPE SYSTEM**  
**RAPID RESPONSE SERIES LFII RESIDENTIAL 4.9 K-FACTOR FLAT PLATE CONCEALED PENDENT (TY3596)**  
**NFPA 13D, 13R, AND 13 HYDRAULIC DESIGN CRITERIA**

## Installation

TYCO RAPID RESPONSE Series LFII Residential Concealed Pendent Sprinklers (TY3596) must be installed in accordance with this section.

### General Instructions

Damage to the fusible Link Assembly during installation can be avoided by handling the sprinkler by the support cup only (i.e., do not apply pressure to the fusible Link Assembly).

A 1/2 inch NPT sprinkler joint should be obtained with a minimum to maximum torque of 7 to 14 lbs.-ft. (9,5 to 19,0 Nm). Higher levels of torque may distort the sprinkler inlet with consequent leakage or impairment of the sprinkler.

Do not attempt to compensate for insufficient adjustment in the Cover Plate / Retainer Assembly by under- or over-tightening the Sprinkler. Readjust the position of the sprinkler fitting to suit.

**Step 1.** The sprinkler must only be installed in the pendent position and with the centerline of the sprinkler perpendicular to the mounting surface.

**Step 2.** Remove the Protective Cap.

**Step 3.** With pipe thread sealant applied to the pipe threads, and using the W-Type 18 Wrench shown in Figure 2, install and tighten the Sprinkler / Support Cup Assembly into the fitting. The W-Type 18 Wrench will accept a 1/2 inch ratchet drive.

**Step 4.** Replace the Protective Cap by pushing it upwards until it bottoms out against the Support Cup. The Protective Cap helps prevent damage to the Deflector and Guide Pins during ceiling installation and/or during application of the finish coating of the ceiling. It may also be used to locate the center of the clearance hole by gently pushing the ceiling material against the center point of the Cap.

**Note:** *As long as the protective Cap remains in place, the system is considered to be "Out Of Service."*

**Step 5.** After the ceiling has been completed with the 2-1/2 inch (63 mm) diameter clearance hole and in preparation for installing the Cover Plate Assembly, remove and discard the Protective Cap, and verify that the Deflector moves up and down freely.

If the sprinkler has been damaged and the Deflector does not move up and down freely, replace the entire sprinkler assembly. Do not attempt to modify or repair a damaged sprinkler.

**Step 6.** Screw on the Cover Plate Assembly until its flange comes in contact with the ceiling.

Do not continue to screw on the Cover Plate Assembly such that it lifts a ceiling panel out of its normal position.

If the Cover Plate Assembly cannot be engaged with the Mounting Cup or the Cover Plate Assembly cannot be engaged sufficiently to contact the ceiling, the Sprinkler Fitting must be repositioned.

## Care and Maintenance

TYCO RAPID RESPONSE Series LFII Residential Concealed Pendent Sprinklers (TY3596) must be maintained and serviced in accordance with this section.

Before closing a fire protection system main control valve for maintenance work on the fire protection system which it controls, permission to shut down the affected fire protection system must be obtained from the proper authorities and all personnel who may be affected by this action must be notified.

Absence of a Cover Plate may delay the sprinkler operation in a fire situation.

When properly installed, there is a nominal 1/8 inch (3,2 mm) air gap between the lip of the Cover Plate and the ceiling, as shown in Figure 3. This air gap is necessary for proper operation of the sprinkler by allowing heat flow from a fire to pass below and above the Cover Plate to help assure appropriate release of the Cover Plate in a fire situation. If the ceiling is to be repainted after the installation of the Sprinkler, care must be exercised to ensure that the new paint does not seal off any of the air gap.

Factory painted Cover Plates must not be repainted. They should be replaced, if necessary, by factory painted units. Non-factory applied paint may adversely delay or prevent sprinkler operation in the event of a fire.

Do not pull the Cover Plate relative to the Enclosure. Separation may result.

Sprinklers which are found to be leaking or exhibiting visible signs of corrosion must be replaced.

Automatic sprinklers must never be painted, plated, coated, or otherwise altered after leaving the factory. Modified or over heated sprinklers must be replaced.

Care must be exercised to avoid damage before, during, and after installation. Sprinklers damaged by dropping, striking, wrench twist/slippage, or the like, must be replaced.

The owner is responsible for the inspection, testing, and maintenance of their fire protection system and devices in compliance with this document, as well as with the applicable standards of the National Fire Protection Association (e.g., NFPA 25), in addition to the standards of any other authorities having jurisdiction. Contact the installing contractor or product manufacturer with any questions.

The owner must assure that the sprinklers are not used for hanging any objects and that the sprinklers are only cleaned by means of gently dusting with a feather duster; otherwise, non-operation in the event of a fire or inadvertent operation may result.

Automatic sprinkler systems should be inspected, tested, and maintained by a qualified Inspection Service in accordance with local requirements and/or national codes.

## Limited Warranty

For warranty terms and conditions, visit  
[www.tyco-fire.com](http://www.tyco-fire.com).

## Ordering Procedure

Contact your local distributor for availability. When placing an order, indicate the full product name and part number (P/N).

### Sprinkler Assemblies

Specify: Series LFII (TY3596) 4.9K Residential Concealed Pendent Sprinkler without Cover Plate Assembly, P/N 51-112-1-160

### Cover Plate Assemblies

Specify: Cover Plate Assembly with (specify) finish for the Series LFII (TY3596) 4.9K Residential Concealed Pendent Sprinkler, P/N (specify):

Ivory (RAL1015) . . . . .	P/N 56-202-0-135
Beige (RAL1001) . . . . .	P/N 56-202-2-135
Pure White * (RAL9010) . . . . .	P/N 56-202-3-135
Signal White ** (RAL9003) . . . . .	P/N 56-202-4-135
Grey White (RAL9002) . . . . .	P/N 56-202-5-135
Brown (RAL8028) . . . . .	P/N 56-202-6-135
Black (RAL9005) . . . . .	P/N 56-202-7-135
Brushed Brass . . . . .	P/N 56-202-8-135
Brushed Chrome . . . . .	P/N 56-202-9-135
Custom Paint . . . . .	P/N 56-202-X-135

\* Eastern Hemisphere sales only  
\*\* Previously known as Bright White

**Note:** All Custom Cover Plates are painted using Sherwin Williams Interior Latex Paint. Contact Tyco Customer Service with any questions related to custom orders.

### Sprinkler Wrench

Specify: W-Type 18 Sprinkler Wrench, P/N 56-000-1-265