

TSP DATA SHEET

Description: 6mm Compression Fittings (DIN 2353)

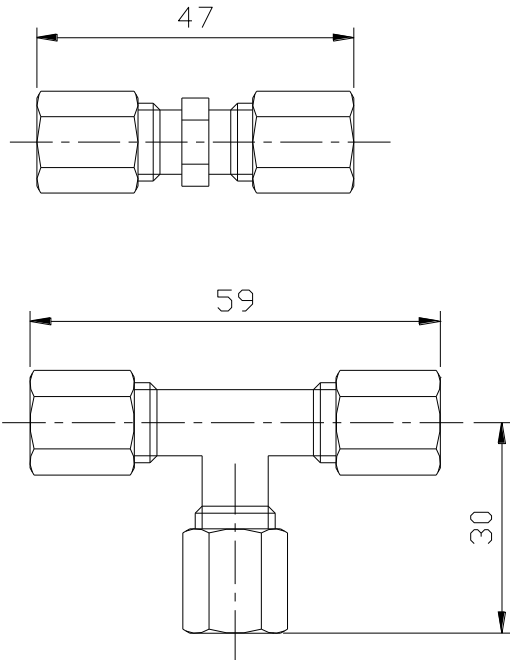

Specification:	Material:	Zinc Plated & Passivated Mild Steel
	Connection:	6mm DIN 2353 Compression Fittings
	Max Working Pressure:	500 bar
	Temperature Range:	0°C to +50°C
	Weight:	Straight – 36g Tee – 64g
	309.011.001 – 6mm Straight Coupling	
	309.013.001 – 6mm Equal Tee	

COMPONENT:	Compression Fittings	PART NO.	309.011.001 309.013.001
SIZE:	6mm	DATA SHEET NO.	DS 20250
FM-200/NOVEC FIRE EXTINGUISHING SYSTEM		ISSUE:	A
		REVISION DATE:	12.04.05
		SHEET NO.	1 / 1

TSP DATA SHEET

Description: 6mm Threaded Compression Fittings (DIN 2353)

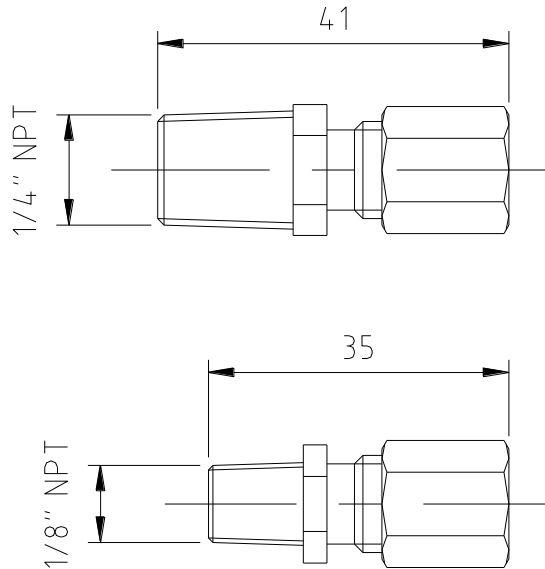

Specification:	Material: Zinc Plated & Passivated Mild Steel Connection: 6mm DIN 2353 Compression Fittings Max Working Pressure: 315 bar Temperature Range: 0°C to +50°C Weight: 1/8" NPT – 23g 1/4" NPT – 35g 309.010.002 – 6mm x 1/8" NPT 309.010.003 – 6mm x 1/8" NPT
-----------------------	--

COMPONENT:	Threaded Compression Fittings	PART NO.	309.010.002/003
SIZE:	6mm	DATA SHEET NO.	DS 20520
FM-200 / NOVEC FIRE EXTINGUISHING SYSTEM		ISSUE:	A
		REVISION DATE:	21.09.05
		SHEET NO.	1 / 1

TSP DATA SHEET

Description: Tee (1/4"BSPP x 1/4"BSPP x 1/4"BSPT)

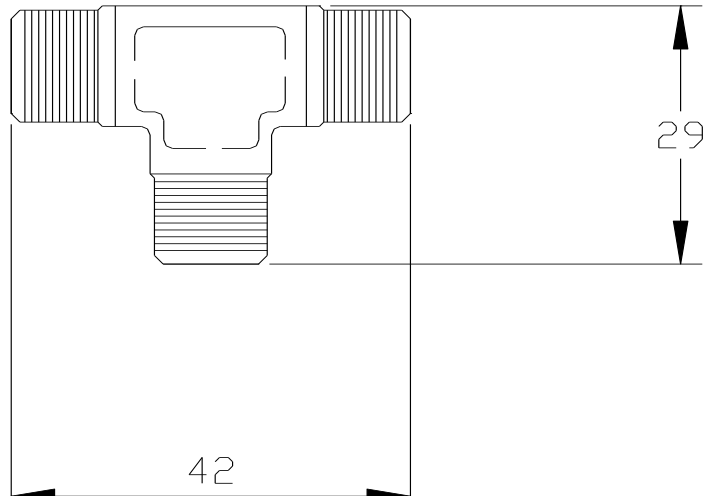

Specification:

Material:	Brass
Connection:	1/4" BSPP(m) x 1/4" BSPP(m) x 1/4" BSPT(m)
Max Working Pressure:	450 bar
Test Pressure:	675 bar
Temperature Range:	-20°C to +55°C
Weight:	75g
Approvals:	UL listed component as part of a UL listed system

COMPONENT:	Tee	PART NO.	309.013.003
SIZE:	1/4" BSPP x 1/4" BSPP x 1/4" BSPT	DATA SHEET NO.	DS 20530
FM-200/NOVEC/CO₂ FIRE EXTINGUISHING SYSTEM		ISSUE :	A
		REVISION DATE:	21.09.05
		SHEET NO.	1 / 1

TSP DATA SHEET

Description: Elbow (1/4"BSPT x 1/4"BSPP)

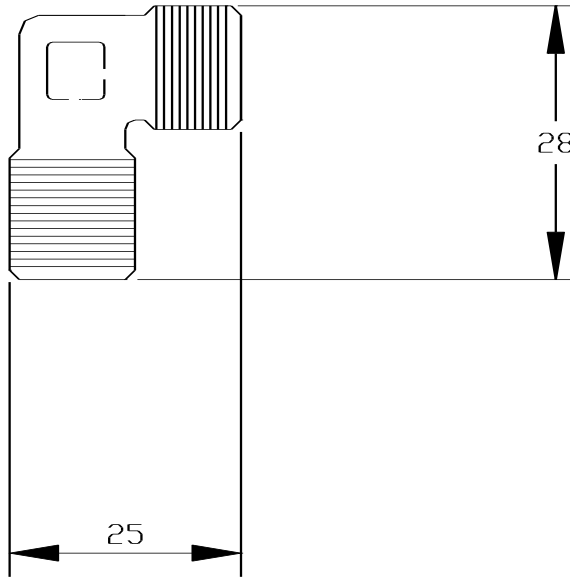

Specification:

Material:	Brass
Connection:	1/4" BSPT(m) x 1/4" BSPP(m)
Max Working Pressure:	450 bar
Test Pressure:	675 bar
Temperature Range:	-20°C to +55°C
Weight:	50g
Approvals:	UL listed component as part of a UL listed system (FM-200)

COMPONENT:	Elbow	PART NO.	309.013.004
SIZE:	1/4" BSPT x 1/4" BSPP	DATA SHEET NO.	DS 20540
FM-200/NOVEC/CO₂ FIRE EXTINGUISHING SYSTEM		ISSUE :	A
		REVISION DATE:	21.09.05
		SHEET NO.	1 / 1

TSP DATA SHEET

Description: Adaptor (1/4" NPT x 1/4" BSP)

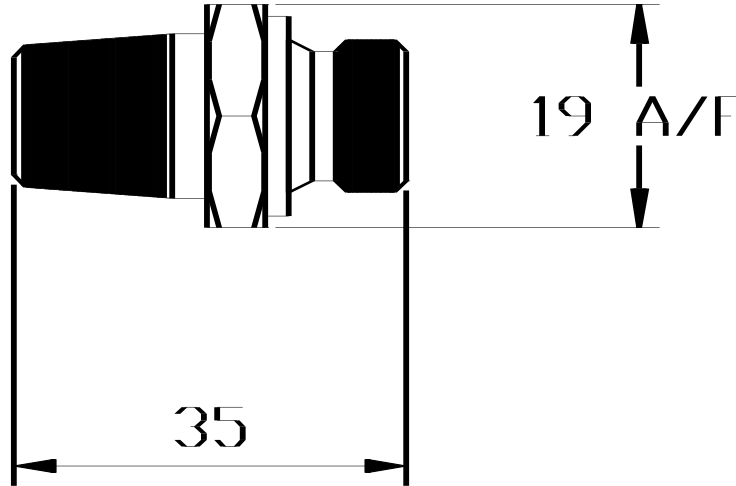

Specification:	Material: Connection: Max Working Pressure: Test Pressure: Temperature Range: Weight:	Zinc Passivated Mild Steel 1/4" NPT male x 1/4" BSPP male 350 bar 525 bar 0°C to +50°C 34g
-----------------------	--	---

COMPONENT:	Adaptor	PART NO.	309.013.006
SIZE:	1/4" NPT x 1/4" BSP	DATA SHEET NO.	DS 20560
FM-200/NOVEC FIRE EXTINGUISHING SYSTEM		ISSUE :	A
		REVISION DATE:	21.09.05
		SHEET NO.	1 / 1

TSP DATA SHEET

Description: 8mm Flexible Pilot Hose

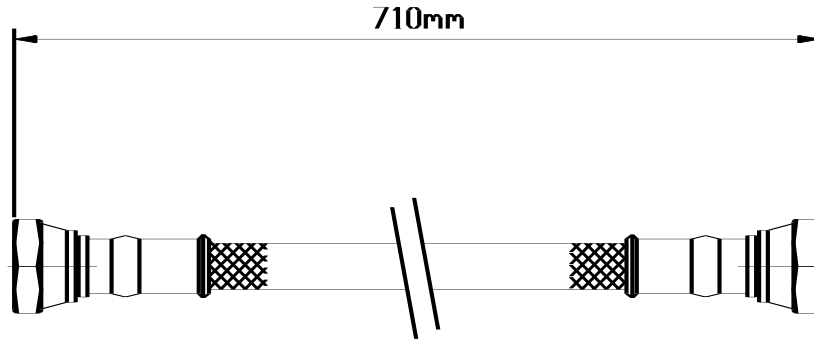

Specification:	Hose Construction: Connection: Max Working Pressure: Min Burst Pressure: Temperature Rating: Max Bend Diameter: Approvals: Internal Diameter: Hose Volume: Weight:	Stainless Steel wire Braid P.T.F.E Inner to BS4976 Zinc Passivated Mild Steel 2-off 1/4" BSP Straight Female Swivel Union 34.5 bar 759 bar -60°C to 260°C 120mm Dia @ 0°C UL listed component as part of a UL listed system (FM-200) 6mm bore 20.07cc 0.15Kg
-----------------------	---	---

COMPONENT:	Flexible Pilot Hose	PART NO.	306.205.003
SIZE:	8mm x 710mm	DATA SHEET NO.	DS 20300
FM-200/NOVEC FIRE EXTINGUISHING SYSTEM		ISSUE :	A
		REVISION DATE:	16.09.05
		SHEET NO.	1 / 1