

Model SW-20 and SW-24 – 11.2 K-factor Extended Coverage Ordinary Hazard Horizontal Sidewall Sprinklers (Standard Response)

General Description

The TYCO Model SW-20 and SW-24, 11.2 K-factor, Extended Coverage Ordinary Hazard (ECHO) Horizontal Sidewall Sprinklers, Standard Response are decorative glass bulb sprinklers designed for use in ordinary hazard occupancies per NFPA 13.

The SW-20 provides protection of coverage areas up to 16 ft. x 20 ft. (320 ft²), whereas the SW-24 provides protection of coverage areas up to 16 ft. x 24 ft. (384 ft²), as compared to standard coverage horizontal sidewall sprinklers having a maximum coverage area of 10 ft. x 10 ft. (100 ft²) for ordinary hazard occupancies.

Horizontal sidewall sprinklers are designed for installation along a wall or the side of a beam and are commonly used instead of pendent or upright sprinklers due to aesthetics or building construction considerations, where piping across the ceiling is not desirable.

Corrosion resistant coatings, where applicable, are utilized to extend the life of copper alloy sprinklers beyond that which would otherwise be obtained when exposed to corrosive atmospheres. Although corrosion resistant coated sprinklers have passed the standard corrosion tests of the applicable approval agencies, the testing is not representative of all possible cor-

rosive atmospheres. Consequently, it is recommended that the end user be consulted with respect to the suitability of these corrosion resistant coatings for any given corrosive environment. The effects of ambient temperature, concentration of chemicals, and gas/chemical velocity, should be considered, as a minimum, along with the corrosive nature of the chemical to which the sprinklers will be exposed.

NOTICE

The Model SW-20 and SW-24 Sprinklers described herein must be installed and maintained in compliance with this document and with the applicable standards of the National Fire Protection Association, in addition to the standards of any authorities having jurisdiction. Failure to do so may impair the performance of these devices.

The owner is responsible for maintaining their fire protection system and devices in proper operating condition. The installing contractor or sprinkler manufacturer should be contacted with any questions.

Sprinkler Identification Number (SIN)

TY5332 - SW-20

TY5337 - SW-24

TY5332 is a re-designation for C5332

TY5337 is a re-designation for C5337

Technical Data

Approvals

UL and C-UL Listed
(Refer to the Design Criteria Section)

Polyester coated sprinklers are UL and C-UL Listed as Corrosion Resistant Sprinklers

NYC under MEA 177-03-E

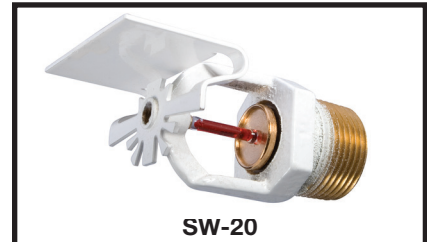

SW-20

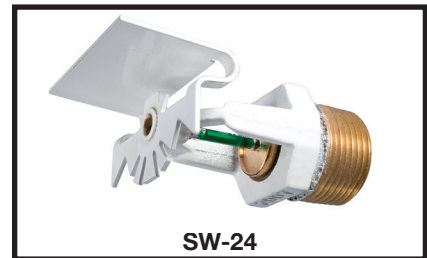

SW-24

Maximum Working Pressure
175 psi (12,1 bar)

Discharge Coefficient
K= 11.2 GPM/psi^{1/2} (161,3 LPM/bar^{1/2})

Temperature Rating
SW-20: 155°F (68°C) & 200°F (93°C)
SW-24: 200°F (93°C)

Finishes
Refer to Table B

Physical Characteristics:

Frame	Bronze
Button	Bronze
Sealing Assembly	Beryllium Nickel w/ TEFLON
Bulb	Glass
Compression Screw	Brass
Deflector	Bronze

IMPORTANT

Always refer to Technical Data Sheet TFP700 for the "INSTALLER WARNING" that provides cautions with respect to handling and installation of sprinkler systems and components. Improper handling and installation can permanently damage a sprinkler system or its components and cause the sprinkler to fail to operate in a fire situation or cause it to operate prematurely.

Components:

- 1 - Frame
- 2 - Button
- 3 - Bulb
- 4 - Compression Screw
- 5 - Sealing Assembly
- 6 - Deflector*

* Temperature rating is indicated on Deflector.

** Pipe thread connections per ISO 7-1 can be provided on special request.

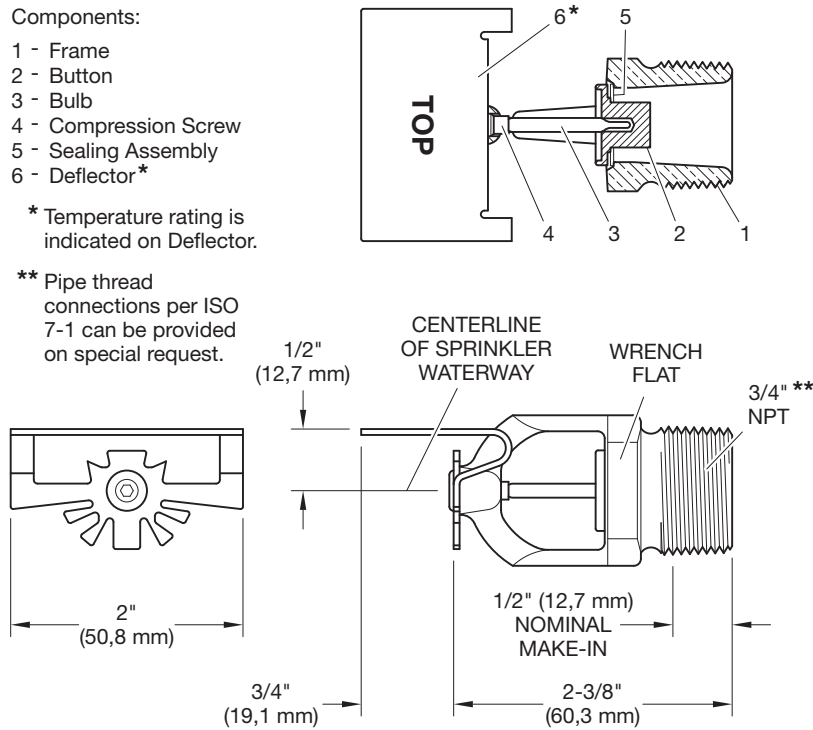

FIGURE 1
MODEL SW-20 (TY5332)
EXTENDED COVERAGE ORDINARY HAZARD
HORIZONTAL SIDEWALL SPRINKLER
11.2 K-FACTOR, 3/4 INCH NPT

Components:

- 1 - Frame
- 2 - Button
- 3 - Bulb
- 4 - Compression Screw
- 5 - Sealing Assembly
- 6 - Deflector*

* Temperature rating is indicated on Deflector.

** Pipe thread connections per ISO 7-1 can be provided on special request.

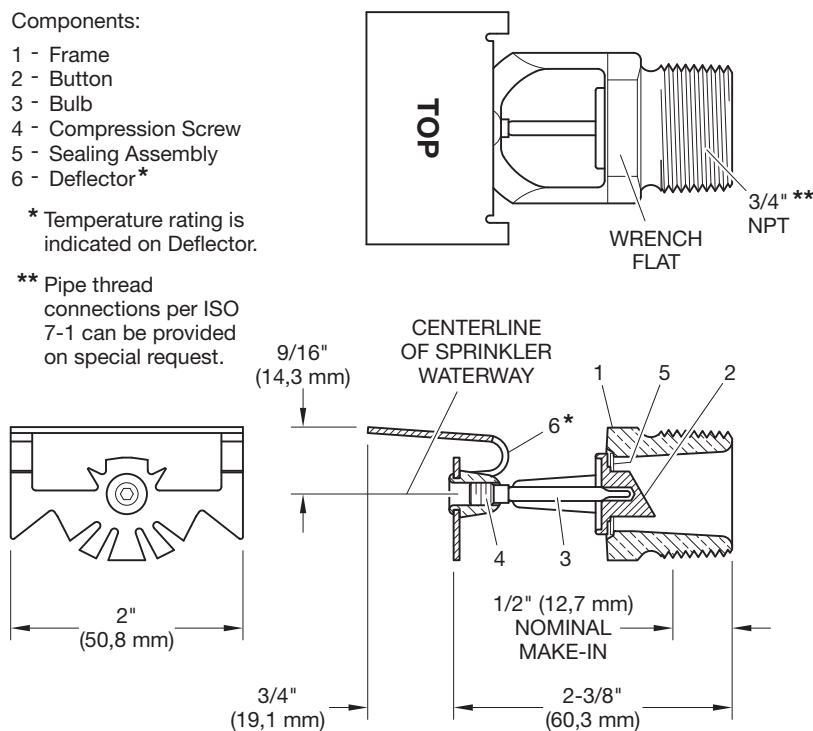

FIGURE 2
MODEL SW-24 (TY5337)
EXTENDED COVERAGE ORDINARY HAZARD
HORIZONTAL SIDEWALL SPRINKLER
11.2 K-FACTOR, 3/4 INCH NPT

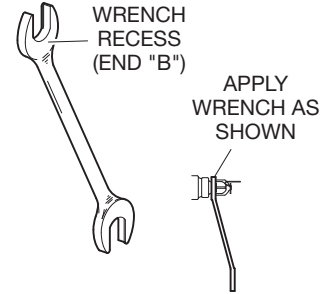

FIGURE 3
W-TYPE 3 SPRINKLER
WRENCH

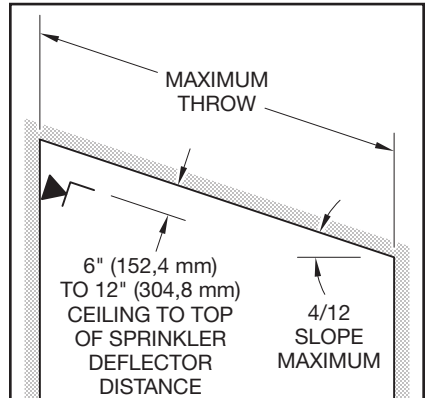

FIGURE 4
SPRINKLER PLACEMENT
UNDER SLOPED CEILINGS IN
LOADING DOCKS

Operation

The glass bulb contains a fluid that expands when exposed to heat. When the rated temperature is reached, the fluid expands sufficiently to shatter the glass bulb, allowing the sprinkler to activate and water to flow.

MODEL SW-20 ECOH HORIZONTAL SIDEWALL SPRINKLER (TY5332) OH Group 1 (0.15 gpm/sq.-ft.)						
Response Rating	Coverage Area⁽¹⁾, Ft. x Ft. (m x m)	Minimum Flow⁽²⁾, GPM (LPM)	Minimum Pressure⁽²⁾, PSI (BAR)	Deflector-To-Ceiling Distance⁽³⁾, In. (mm)	Sprinkler Temperature Rating, °F	Minimum Spacing⁽⁴⁾, Ft. (m)
Standard	16 x 16 (4,9 x 4,9)	38 (144)	11.5 (0,79)	6 to 12 (150 to 300)	155, 200	8 (2,4)
Standard	16 x 18 (4,9 x 5,5)	43 (163)	14.7 (1,01)	6 to 12 (150 to 300)	155, 200	8 (2,4)
Standard	16 x 20 (4,9 x 6,1)	48 (182)	18.4 (1,27)	6 to 12 (150 to 300)	155, 200	8 (2,4)

MODEL SW-20 ECOH HORIZONTAL SIDEWALL SPRINKLER (TY5332) OH Group 2 (0.20 gpm/sq.-ft.)						
Response Rating	Coverage Area⁽¹⁾, Ft. x Ft. (m x m)	Minimum Flow⁽²⁾, GPM (LPM)	Minimum Pressure⁽²⁾, PSI (BAR)	Deflector-To-Ceiling Distance⁽³⁾, In. (mm)	Sprinkler Temperature Rating, °F	Minimum Spacing⁽⁴⁾, Ft. (m)
Standard	16 x 16 (4,9 x 4,9)	51 (193)	20.7 (1,43)	6 to 12 (150 to 300)	155, 200	8 (2,4)
Standard	16 x 18 (4,9 x 5,5)	58 (220)	26.8 (1,85)	6 to 12 (150 to 300)	155, 200	8 (2,4)
Standard	16 x 20 (4,9 x 6,1)	64 (242)	32.7 (2,25)	6 to 12 (150 to 300)	155, 200	8 (2,4)

MODEL SW-24 ECOH HORIZONTAL SIDEWALL SPRINKLER (TY5337) OH Group 1 (0.15 gpm/sq.-ft.)						
Response Rating	Coverage Area⁽¹⁾, Ft. x Ft. (m x m)	Minimum Flow⁽²⁾, GPM (LPM)	Minimum Pressure⁽²⁾, PSI (BAR)	Deflector-To-Ceiling Distance⁽³⁾, In. (mm)	Sprinkler Temperature Rating, °F	Minimum Spacing⁽⁴⁾, Ft. (m)
Standard	16 x 22 (4,9 x 6,7)	53 (200)	22.4 (1,54)	6 to 12 (150 to 300)	200	8 (2,4)
Standard	16 x 24 (4,9 x 7,3)	58 (220)	26.8 (1,85)	6 to 12 (150 to 300)	200	8 (2,4)

MODEL SW-24 ECOH HORIZONTAL SIDEWALL SPRINKLER (TY5337) OH Group 2 (0.20 gpm/sq.-ft.)						
Response Rating	Coverage Area⁽¹⁾, Ft. x Ft. (m x m)	Minimum Flow⁽²⁾, GPM (LPM)	Minimum Pressure⁽²⁾, PSI (BAR)	Deflector-To-Ceiling Distance⁽³⁾, In. (mm)	Sprinkler Temperature Rating, °F	Minimum Spacing⁽⁴⁾, Ft. (m)
Standard	16 x 22 (4,9 x 6,7)	71 (269)	40.2 (2,77)	6 to 12 (150 to 300)	200	8 (2,4)
Standard	16 x 24 (4,9 x 7,3)	77 (291)	47,3 (3,26)	6 to 12 (150 to 300)	200	8 (2,4)

NOTES

1. Backwall (where sprinkler is located) by sidewall (length of throw).
2. Requirement is based on minimum flow in GPM from each sprinkler. The indicated residual pressures are based on the nominal K-factor.
3. The centerline of the sprinkler waterway is located below the deflector as shown in Figures 1 and 2.
4. Minimum spacing is for lateral distance between sprinklers located along a single wall. Otherwise adjacent sprinklers (i.e., sidewall sprinklers on an adjacent wall, on an opposite wall, or pendent sprinklers) must be located outside of the maximum listed protection area of the extended coverage sidewall sprinkler being utilized.

TABLE A
UL AND C-UL LISTING COVERAGE AND FLOW RATE CRITERIA

Design Criteria

The TYCO Model SW-20 and SW-24, 11.2 K-factor, Extended Coverage Ordinary Hazard (ECOH) Horizontal Sidewall Sprinklers are for use in ordinary hazard occupancies with non-combustible unobstructed construction and with a ceiling slope not exceeding 2 inches per foot (9.2°), using the design criteria provided in Table A, (as well as any additional requirements specified in NFPA 13 for Extended Coverage Sidewall Spray Sprinklers).

A 36 inch (914 mm) clearance must be maintained between the top of the sprinkler deflector and any miscellaneous storage.

The SW-20 and SW-24 may be installed on sloped ceilings in loading docks with a maximum roof slope of 4 inches per foot (18.4°) as shown in Figure 4 and using the design criteria provided in Table A.

The SW-20 and SW-24 can be used only for exposed applications. The SW-20 and SW-24 cannot be recessed.

Installation

The TYCO Model SW-20 and SW-24, 11.2 K-factor, Extended Coverage Ordinary Hazard (ECOH) Horizontal Sidewall Sprinklers must be installed in accordance with this section.

General Instructions

Do not install any bulb type sprinkler if the bulb is cracked or there is a loss of liquid from the bulb. With the sprinkler held horizontally, a small air bubble should be present. The diameter of the air bubble is approximately 1/16 in. (1,6 mm).

A leak tight 1/2 inch NPT sprinkler joint should be obtained with a minimum to maximum torque of 7 to 14 ft.-lbs. (9,5 to 19,0 Nm). Higher levels of torque can distort the sprinkler Inlet with consequent leakage or impairment of the sprinkler.

Do not attempt to compensate for insufficient adjustment in the Sprinkler by under- or over-tightening the Sprinkler/Support Cup Assembly. Re-adjust the position of the sprinkler fitting to suit.

Step 1. Horizontal sidewall sprinklers are to be installed with their centerline perpendicular to the back wall and parallel to the ceiling. The word "TOP" on the deflector is to face towards the ceiling.

Step 2. With pipe thread sealant applied to the pipe threads, hand tighten the sprinkler into the sprinkler fitting.

Step 3. Tighten the sprinkler into the sprinkler fitting using only the W-Type 3 (End B) Sprinkler Wrench (Ref. Figure 3). With reference to Figures 1 and 2, the W-Type 3 Sprinkler Wrench is to be applied to the sprinkler wrench flats

Care and Maintenance

The TYCO Model SW-20 and SW-24, 11.2 K-factor, Extended Coverage Ordinary Hazard (ECOH) Horizontal Sidewall Sprinklers must be maintained and serviced in accordance with this section.

Before closing a fire protection system main control valve for maintenance work on the fire protection system that it controls, obtain permission to shut down the affected fire protection system from the proper authorities and notify all personnel who may be affected by this action.

The owner is responsible for the inspection, testing, and maintenance of their fire protection system and devices in compliance with this document, as well as with the applicable standards of the National Fire Protection Association (e.g., NFPA 25), in addition to the standards of any other authorities having jurisdiction. Contact the installing contractor or sprinkler manufacturer regarding any questions.

Automatic sprinkler systems should be inspected, tested, and maintained by a qualified Inspection Service in accordance with local requirements and/or national code.

Absence of an escutcheon, which is used to cover a clearance hole, may delay the time to sprinkler operation in a fire situation.

Automatic sprinklers must never be painted, plated, coated or otherwise altered after leaving the factory. Modified sprinklers must be replaced. Sprinklers that have been exposed to corrosive products of combustion, but have not operated, should be replaced if they cannot be completely cleaned by wiping the sprinkler with a cloth or by brushing it with a soft bristle brush.

Care must be exercised to avoid damage to the sprinklers before, during, and after installation. Sprinklers damaged by dropping, striking, wrench twist/slippage, or the like, must be replaced. Also, replace any sprinkler that has a cracked bulb or that has lost liquid from its bulb. (Ref. Installation Section).

Frequent visual inspections are recommended to be initially performed for corrosion resistant coated sprinklers, after the installation has been completed, to verify the integrity of the corrosion resistant coating. Thereafter, annual inspections per NFPA 25 should suffice; however, instead of inspecting from the floor level, a random sampling of close-up visual inspections should be made, so as to better determine the exact sprinkler condition and the long term integrity of the corrosion resistant coating as it may be affected by the corrosive conditions present.

Limited Warranty

For warranty terms and conditions, visit www.tyco-fire.com.

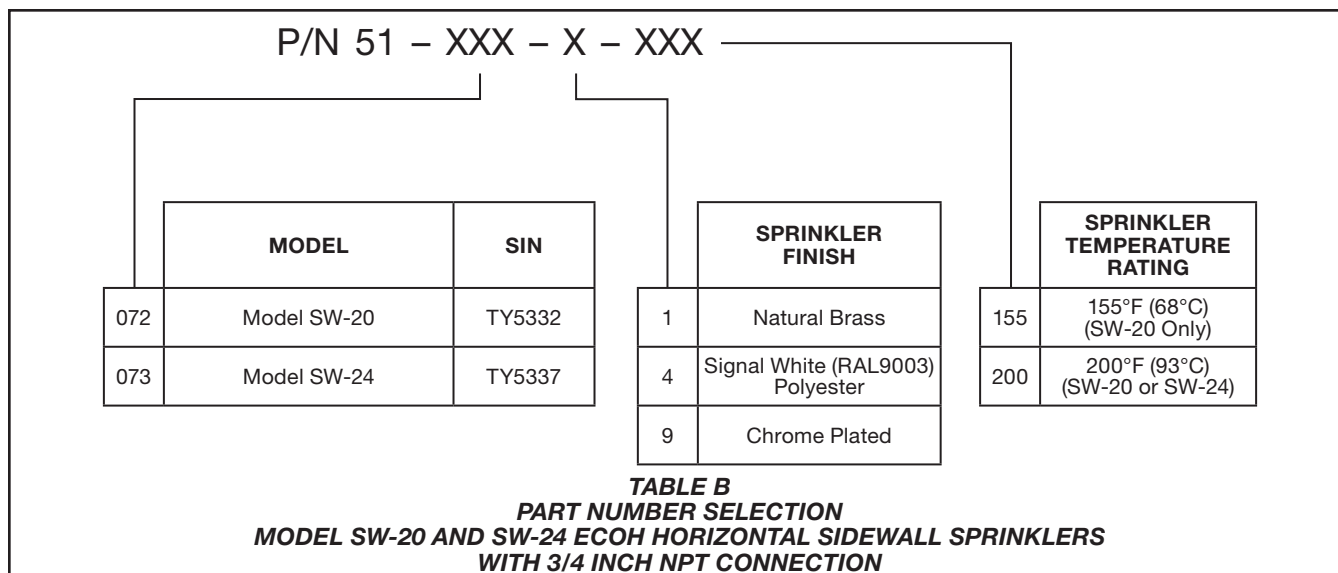

Ordering Procedure

Contact your local distributor for availability. When placing an order, indicate the full product name and Part Numbers (P/N).

Sprinkler Assemblies with NPT

Thread Connections:

Specify: Model (specify) ECOH Horizontal Sidewall Sprinkler, SIN (specify), (specify) temperature rating, (specify) finish, P/N (specify from Table B)

Sprinkler Wrench:

Specify: W-Type 3 Sprinkler Wrench, P/N 56-895-1-001

