



# Series TY-FRB — 5.6 K-factor Upright and Pendent Intermediate Level Sprinklers Quick Response

## General Description

The Series TY-FRB, 5.6 K-factor Upright and Pendent Intermediate Level Sprinklers described in this data sheet are automatic sprinklers of the “quick response” 3 mm frangible bulb type. They are “standard spray” sprinklers intended for use in fire sprinkler systems designed in accordance with the standard installation rules recognized by the applicable Listing or Approval agency (e.g., UL Listing is based on NFPA requirements). Both the Upright and Pendent Sprinklers produce a hemispherical water distribution pattern below the deflector.

Intermediate Level Sprinklers are primarily designed for use in rack storage sprinkler systems where their thermally sensitive elements must be shielded from the water spray of higher elevation sprinklers that could operate earlier during a fire. Intermediate Level Sprinklers are also used in other applications such as beneath open gridded catwalks.

For additional Series TY-FRB Sprinkler information, see Technical Data Sheet TFP172. For additional Guard and Shield information, see Technical Data Sheet TFP780.

### NOTICE

The Series TY-FRB Sprinklers described herein must be installed and maintained in compliance with this document, as well as with the applicable standards of the National Fire

### IMPORTANT

Always refer to Technical Data Sheet TFP700 for the “INSTALLER WARNING” that provides cautions with respect to handling and installation of sprinkler systems and components. Improper handling and installation can permanently damage a sprinkler system or its components and cause the sprinkler to fail to operate in a fire situation or cause it to operate prematurely.

Protection Association, in addition to the standards of any other authorities having jurisdiction. Failure to do so may impair the performance of these devices.

The owner is responsible for maintaining their fire protection system and devices in proper operating condition. The installing contractor or sprinkler manufacturer should be contacted with any questions.

## Sprinkler Identification Numbers

TY313 . . . . . Upright 5.6K, 1/2” NPT  
TY323 . . . . . Pendent 5.6K, 1/2” NPT

## Technical Data

### Approvals

UL and C-UL Listed  
FM Approved  
(Refer to Table A for complete approval information.)

### Maximum Working Pressure

175 psi (12,1 bar)  
250 psi (17,2 bar)\*

\* The Maximum Working Pressure of 250 psi (17,2 bar) only applies to the listing by Underwriters Laboratory.

### Discharge Coefficient

K=5.6 GPM/psi<sup>1/2</sup> (80,6 LPM/bar<sup>1/2</sup>)

### Temperature Ratings

Refer to Table A

### Finishes

TY-FRB Sprinkler . . . . . Brass  
G1/S1 Guard with Shield . . . . Red or Zinc  
G1 Guard . . . . . Red or Zinc  
S2 Shield . . . . . Zinc



### Physical Characteristics

Frame . . . . . Bronze  
Button . . . . . Brass/Copper  
Sealing Assembly . . . . . Stainless Steel w/TEFLON  
Bulb . . . . . Glass  
Compression Screw . . . . . Bronze  
Deflector . . . . . Copper  
G1 and G1/S1 Guard . . . . Painted or Plated Steel  
S2 Shield . . . . . Plated Steel

## Operation

The glass bulb contains a fluid which expands when exposed to heat. When the rated temperature is reached, the fluid expands sufficiently to shatter the glass bulb, allowing the sprinkler to activate and water to flow.

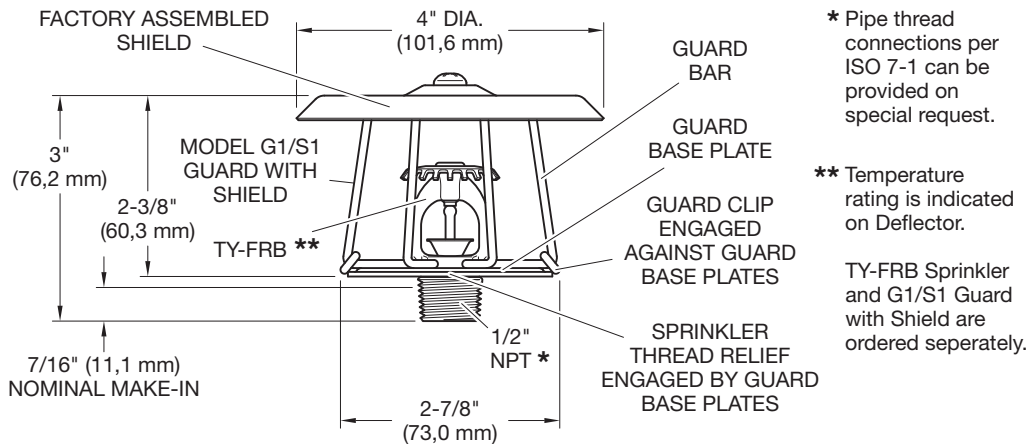

\* Pipe thread connections per ISO 7-1 can be provided on special request.

\*\* Temperature rating is indicated on Deflector.

TY-FRB Sprinkler and G1/S1 Guard with Shield are ordered separately.

**FIGURE 1**  
**SERIES TY-FRB UPRIGHT (TY313) INTERMEDIATE LEVEL SPRINKLER WITH G1/S1 GUARD WITH SHIELD**

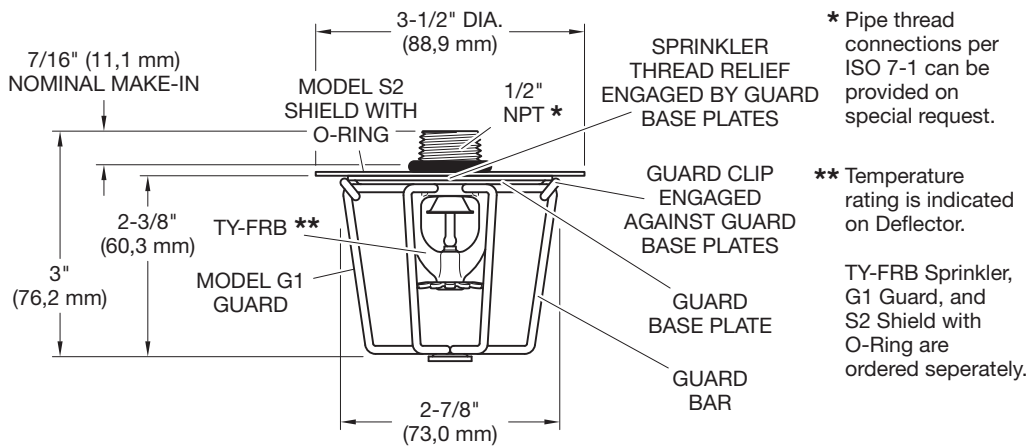

\* Pipe thread connections per ISO 7-1 can be provided on special request.

\*\* Temperature rating is indicated on Deflector.

TY-FRB Sprinkler, G1 Guard, and S2 Shield with O-Ring are ordered separately.

**FIGURE 2**  
**SERIES TY-FRB PENDENT (TY323) INTERMEDIATE LEVEL SPRINKLER WITH S2 SHIELD AND G1 GUARD**

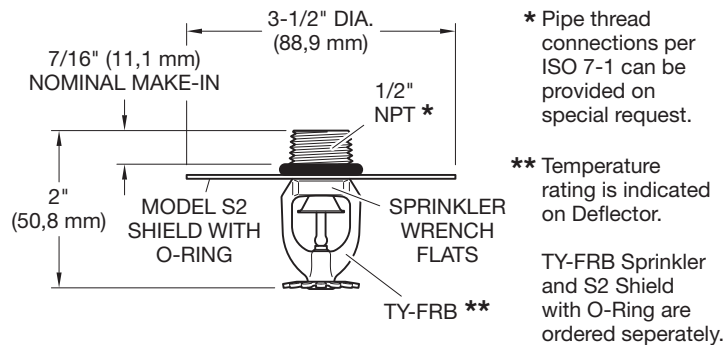

\* Pipe thread connections per ISO 7-1 can be provided on special request.

\*\* Temperature rating is indicated on Deflector.

TY-FRB Sprinkler and S2 Shield with O-Ring are ordered separately.

**FIGURE 3**  
**SERIES TY-FRB PENDENT (TY323) INTERMEDIATE LEVEL SPRINKLER WITH S2 SHIELD**

K	TYPE	TEMP.	BULB LIQUID	SPRINKLER FINISH
				NATURAL BRASS
5.6 1/2" NPT	UPRIGHT (TY313) with Guard/ Shield (G1/S1)	135°F (57°C)	Orange	1, 2, 3
		155°F (68°C)	Red	
		175°F (79°C)	Yellow	
		200°F (93°C)	Green	
		286°F (141°C)	Blue	
	PENDENT (TY323) with Guard/ Shield (G1/S2) or Shield only (S2)	135°F (57°C)	Orange	
		155°F (68°C)	Red	
		175°F (79°C)	Yellow	
		200°F (93°C)	Green	
		286°F (141°C)	Blue	

**NOTES:**

1. Listed by Underwriters Laboratories, Inc. (UL).
2. Listed by Underwriters Laboratories, Inc. for use in Canada (C-UL).
3. Approved by Factory Mutual Research Corporation (FM).

**TABLE A**  
**LABORATORY LISTINGS AND APPROVALS**

WITH SPRINKLER PROPERLY INSTALLED,  
CAREFULLY SPREAD BASE PLATES APART AND FIT  
GUARD ONTO SPRINKLER ENGAGING SPRINKLER  
THREAD RELIEF BY BASE PLATES

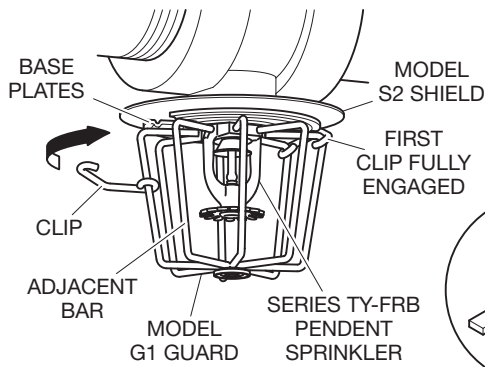

SWIVEL CLIPS OVER ADJACENT  
BARS AND SLIDE TOWARD BASE  
PLATES UNTIL SNUG

INSTALLATION TOOL  
(SHIPPED WITH  
GUARDS)

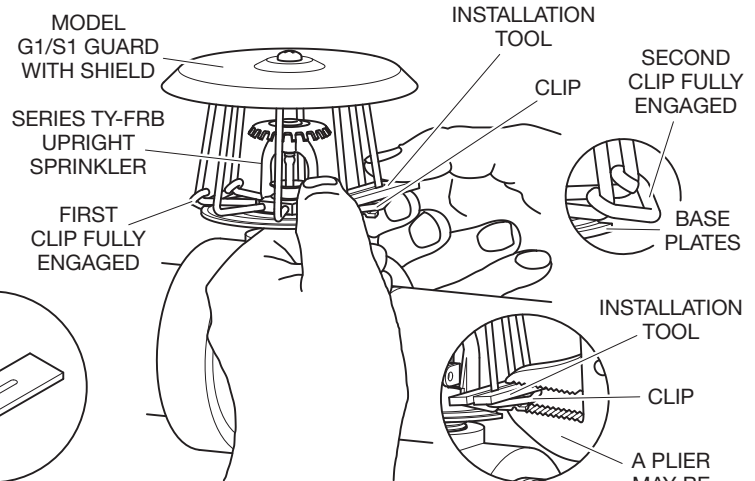

WITH INSTALLATION TOOL APPLIED OVER  
ADJACENT BARS, PRESS SECOND CLIP  
TOWARD BASE PLATES UNTIL FULLY ENGAGED

A PLIER  
MAY BE  
USED

**FIGURE 4**  
**INSTALLATION PROCEDURES FOR MODEL G1 GUARD AND S2 SHIELD (PENDENT SPRINKLER)  
AND MODEL G1/S1 GUARD WITH SHIELD (UPRIGHT SPRINKLER)**

## Design Criteria

The Series TY-FRB, 5.6 K-factor Upright and Pendent Intermediate Level Sprinklers are intended for fire protection systems designed in accordance with the standard installation rules recognized by the applicable Listing or Approval agency (e.g., UL Listing is based on the requirements of NFPA 13, and FM Approval is based on the requirements of FM's Loss Prevention Data Sheets).

## Installation

The Series TY-FRB, 5.6 K-factor Upright and Pendent Intermediate Level Sprinklers must be installed in accordance with this section:

### General Instruction

Do not install any bulb type sprinkler if the bulb is cracked or there is a loss of liquid from the bulb. With the sprinkler held horizontally, a small air bubble should be present. The diameter of the air bubble is approximately 1/16 inch (1,6 mm) for the 135°F (57°C) to 3/32 inch (2,4 mm) for the 286°F (141°C) temperature ratings.

A leak tight 1/2 inch NPT sprinkler joint should be obtained with a torque of 7 to 14 ft.-lbs. (9,5 to 19,0 Nm). Higher levels of torque may distort the sprinkler inlet and cause leakage or impairment of the sprinkler.

### Upright Sprinklers

The Series TY-FRB Intermediate Level Upright Sprinklers must be installed in accordance with the following instructions.

**Step 1.** With pipe thread sealant applied to the pipe threads, hand tighten the sprinkler into the sprinkler fitting.

**Step 2.** Tighten the sprinkler into the sprinkler fitting using only the W-Type 6 Sprinkler Wrench (Ref. Figure 5). With reference to Figure 1, the W-Type 6 Sprinkler Wrench is to be applied to the wrench flats.

**Step 3.** Mount the Model G1/S1 Guard with Shield on the sprinkler. With the Clips loose, spread the two halves of the Sprinkler Guard enough to pass by the sprinkler deflector from the side.

**Step 4.** Spread the two halves of the Sprinkler Base Plates enough to pass over the sprinkler Thread Relief portion of the sprinkler. (Refer to Figure 1.)

**Step 5.** With the Sprinkler Guard positioned on the Thread Relief portion of the sprinkler, engage the Bars with Clips from opposing Guard Halves, then slide the Clips up until they are seated against the Base Plates, completing the installation as shown in Figure 1 and 4.

**NOTE:** To help assist with the sliding of the Clips, use the Guard Installation Tool as shown in Figure 4. Additionally, pliers can be used to facilitate the final seating of the Clips.

### NOTICE

*The Clips must seat against the Base Plates to be fully seated in order to complete the installation. The Model G1/S1 Guard with Shield may be located in any position relative to the sprinkler frame arms.*

### Pendent Sprinklers

The Series TY-FRB Intermediate Level Pendent Sprinklers must be installed in accordance with the following instructions.

**Step A.** Thread the S2 Shield on to the sprinkler threads with the stamped markings toward the deflector and just to the end of the threads. The final assembly step is easier to accomplish if the Shield is not disengaged by continuing to turn the Shield past the threads.

**Step B.** Roll the O-Ring over the sprinkler threads until it seats against the Shield.

**Step C.** With pipe thread sealant applied to the pipe threads, hand tighten the sprinkler into the sprinkler fitting.

**Step D.** Tighten the sprinkler into the sprinkler fitting using only the W-Type 6 Sprinkler Wrench (Ref. Figure 5). With reference to Figure 2 or 3, the W-Type 6 Sprinkler Wrench is to be applied to the wrench flats.

**Step E.** Rotate the S2 Shield clockwise (looking up) so that it slightly compresses the O-Ring between the Shield and sprinkler fitting.

**Note:** Installation of the S2 Shield only is completed at this point (Ref. Figure 3). If installing a G1 Guard, proceed to the next step.

**Step F.** Mount the Model G1 Guard on the sprinkler. With the Clips loose, spread the two halves of the Sprinkler Guard enough to pass by the sprinkler deflector from the side.

**Step G.** Spread the two halves of the Sprinkler Base Plates enough to pass over the sprinkler Thread Relief portion of the sprinkler. (Refer to Figure 2.)

**Step H.** With the Sprinkler Guard positioned on the Thread Relief portion of the sprinkler, engage the Bars with Clips from opposing Guard Halves, then slide the Clips up until they are seated against the Base Plates, completing the installation as shown in Figure 2 and 4.

**NOTE:** To help assist with the sliding of the Clips, use the Guard Installation Tool as shown in Figure 4. Additionally, pliers can be used to facilitate the final seating of the Clips.

### NOTICE

*The Clips must seat against the Base Plates to be fully seated in order to complete the installation. The Model G1 Guard may be located in any position relative to the sprinkler frame arms.*

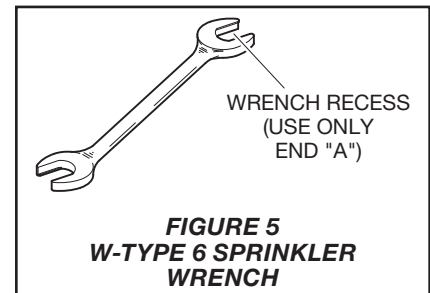

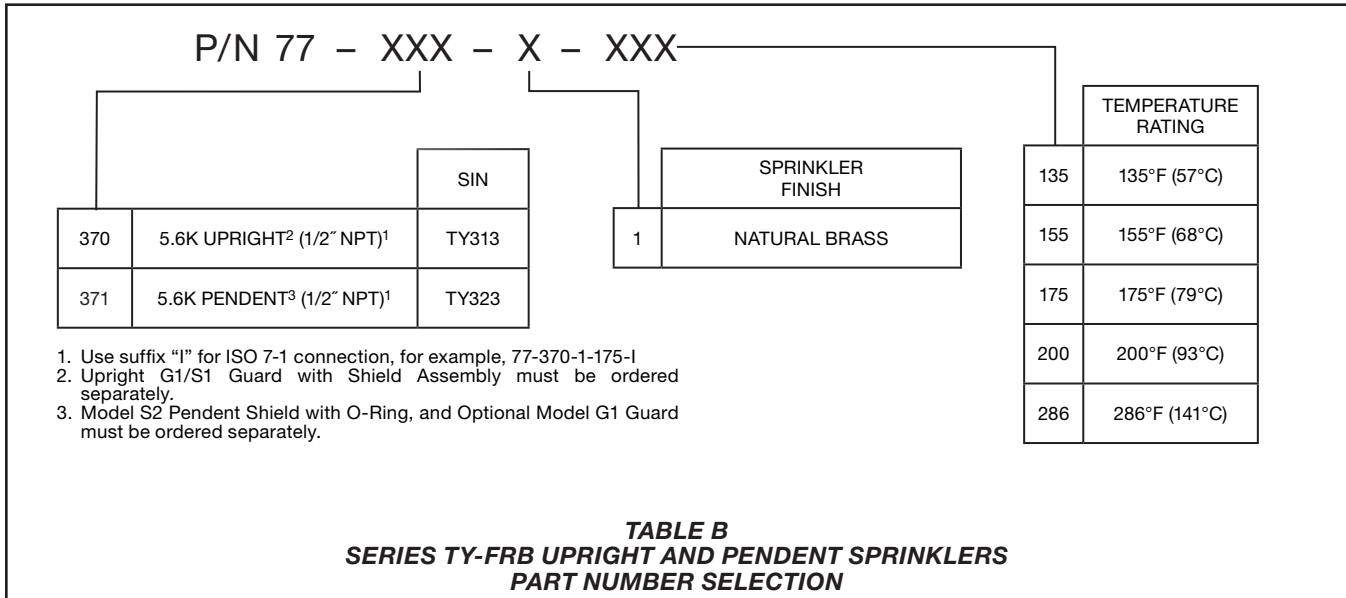

## Care and Maintenance

The Series TY-FRB, 5.6 K-factor Upright and Pendent Intermediate Level Sprinklers must be maintained and serviced in accordance with this section:

Before closing a fire protection system main control valve for maintenance work on the fire protection system that it controls, permission to shut down the affected fire protection system must be obtained from the proper authorities and all personnel who may be affected by this action must be notified.

Sprinklers that are found to be leaking or exhibiting visible signs of corrosion must be replaced.

Automatic sprinklers must never be painted, plated, coated or otherwise altered after leaving the factory. Modified sprinklers must be replaced. Sprinklers that have been exposed to corrosive products of combustion, but have not operated, should be replaced if they cannot be completely cleaned by wiping the sprinkler with a cloth or by brushing it with a soft bristle brush.

Care must be exercised to avoid damage to the sprinklers -before, during, and after installation. Sprinklers damaged by dropping, striking, wrench twist/slippage, or the like, must be replaced. Also, replace any sprinkler that has a cracked bulb or that has lost liquid from its bulb. (Ref. Installation Section).

The owner is responsible for the inspection, testing, and maintenance of their fire protection system and de-

vices in compliance with this document, as well as with the applicable standards of the National Fire Protection Association (e.g., NFPA 25), in addition to the standards of any other authorities having jurisdiction. The installing contractor or sprinkler manufacturer should be contacted relative to any questions.

It is recommended that automatic sprinkler systems be inspected, tested, and maintained by a qualified Inspection Service in accordance with local requirements and/or national code.

## Ordering Procedure

Contact your local distributor for availability. When placing an order, indicate the full product name and Part Numbers (P/N).

Series TY-FRB Intermediate Sprinklers are comprised of separately ordered components: Sprinkler, Guard, and/or Shield.

### Upright Sprinkler Assemblies with NPT Thread Connections

Specify: Series TY-FRB Upright Intermediate Level Sprinkler, K=5.6, (specify SIN), Quick Response, (specify) temperature rating, (specify) finish, P/N (specify from Table B)

### Pendent Sprinkler Assemblies with NPT Thread Connections

Specify: Series TY-FRB Pendent Sprinkler, K=5.6, (specify SIN), Quick Response, (specify) temperature rating, (specify) finish, P/N (specify from Table B).

### Model G1/S1 Guard with Shield

Specify: Model G1/S1 Sprinkler Guard with Shield, (specify) finish, P/N (specify).

Red Painted . . . . . P/N 56-938-1-066  
 Zinc Chromate . . . . . P/N 56-938-9-066

### Model G1 Sprinkler Guard

Specify: Model G1 Sprinkler Guard, (specify) finish, P/N (specify).

Red Painted . . . . . P/N 56-938-1-001  
 Zinc Chromate . . . . . P/N 56-938-9-001

### Model S2 Pendent Shield with O-Ring

Specify: Model S2 Pendent Shield with O-Ring, 1/2" NPT, Series TY-FRB Pendent Sprinklers, P/N 56-070-9-332.

### Sprinkler Wrench

Specify: W-Type 6 Sprinkler Wrench, P/N 56-000-6-387.

### Additional\* Guard Installation Tools

Specify: Guard Installation Tool for Model G1 Sprinkler Guards, P/N 56-000-8-597.

\* The Guard Installation Tool is included with orders in original carton quantities.