

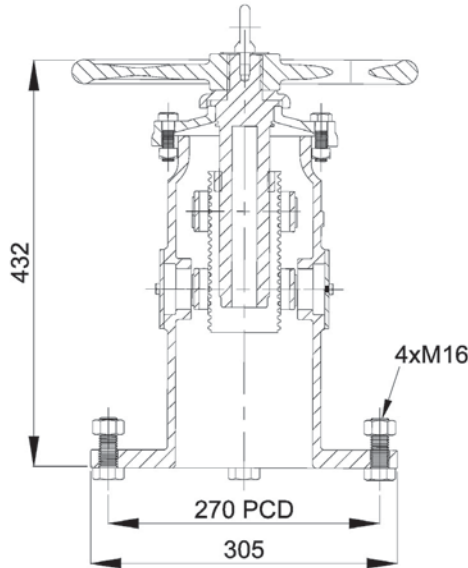

WP Wall Post Indicator

UL Listed / FM Approved

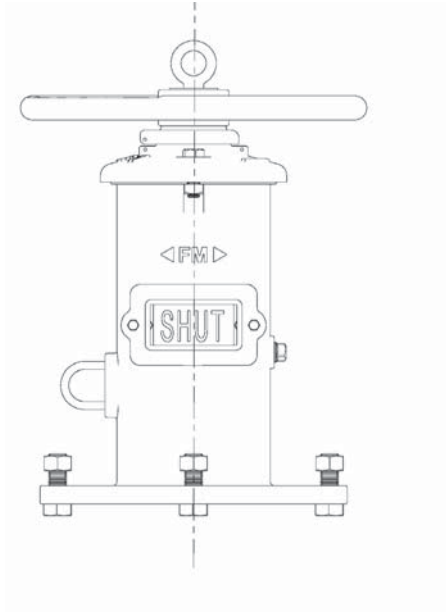

Material Specification

Item	Material
Eye Bolt	Cast Steel ASTM A307B
Hex Bolt, 1/2-13UNC	Cast Steel ASTM A307B
Hex Nut 1/2-13UNC	Cast Steel ASTM A307B
Washer	Cast Steel ASTM A570Gr.33
Handwheel	Ductile Iron ASTM A536
Snap Ring	AISI 1066
Cover	Cast Iron ASTM A126 B
Operating Nut	Bronze ASTM B62
Target Nut	Bronze ASTM B62
Window Glass	Plexiglas
Gasket	PTFE
Hex Bolt M8x15	Cast Steel ASTM A307B
Plug	Malleable Iron
Target	Cast Aluminium
Hex Bolt M6x15	Cast Steel ASTM A307B
Hex Nut M6	Cast Steel ASTM A307B
Body	Cast Iron AISI A126 B
Stem 1" Sq	Cast Steel AISI 1045
Crane Coupling	Ductile Iron ASTM A536
Cotter Pin $\phi 1/4"$ x 3"	Stainless Steel AISI 304

Notes

1. Remove the top section from the top of the Indicator Post assembly.
2. Cut the 1" square stem bar to suit valve position.
3. Set the "OPEN" and "SHUT" targets for the appropriate valves size.
4. Reattach the Top Section to the top of the Indicator Post assembly.

