

RAPID RESPONSE Series LFII Residential Sprinklers 4.9 K-factor Flat-Plate Concealed Pendent Wet Pipe and Dry Pipe Systems

General Description

The TYCO RAPID RESPONSE Series LFII Residential Flat-Plate Concealed Pendent Sprinklers (TY2524) are decorative, fast response, fusible solder sprinklers designed for use in residential occupancies such as homes, apartments, dormitories, and hotels.

The Cover Plate/Retainer Assembly conceals the sprinkler operating components above the ceiling. The flat profile of the Cover Plate provides the optimum aesthetically appealing sprinkler design. Additionally, the concealed design of the Series LFII Residential Flat-Plate Concealed Pendent Sprinklers provides 1/2 inch (12,7 mm) vertical adjustment. This adjustment provides a measure of flexibility when cutting fixed sprinkler drops.

The Series LFII Residential Flat-Plate Concealed Pendent Sprinklers are intended for use in the following systems:

- wet and dry pipe residential sprinkler systems for one- and two-family dwellings and mobile homes per NFPA 13D
- wet and dry pipe residential sprinkler systems for residential occupancies up to and including four stories in height per NFPA 13R
- wet and dry pipe sprinkler systems for the residential portions of any occupancy per NFPA 13

The Series LFII Residential Sprinklers have been designed with heat sensitivity and water distribution characteristics

proven to help in the control of residential fires and to improve the chance for occupants to escape or be evacuated.

The Series LFII Residential Flat-Plate Concealed Pendent Sprinklers are shipped with a Disposable Protective Cap. The Protective Cap protects the sprinkler during ceiling installation or finish. After ceiling installation is complete, the Protective Cap is removed and the Cover Plate/Retainer Assembly is installed. Removing the Protective Cap is required for proper sprinkler performance.

Dry Pipe System Application

The Series LFII Residential Flat-Plate Concealed Pendent Sprinkler offers a laboratory approved option for designing dry pipe residential sprinkler systems, whereas, most residential sprinklers are laboratory approved for wet systems only.

Through extensive testing, it has been determined that the number of design sprinklers (hydraulic design area) for the Series LFII Residential Flat-Plate Concealed Sprinklers (TY2524) need not be increased over the number of design sprinklers (hydraulic design area) specified for wet pipe sprinkler systems, as is customary for density/area sprinkler systems designed per NFPA 13, 13D, or 13R.

Consequently, the Series LFII Residential Flat-Plate Concealed Sprinklers (TY2524) offer the features of non-water filled pipe in addition to not having to increase the number of design sprinklers (hydraulic design area) for systems designed to NFPA 13, 13D, or 13R.

NOTICE

The Series LFII Residential Flat-Plate Concealed Pendent Sprinklers (TY2524) described herein must be installed and maintained in compliance with this document and the applicable standards of the National Fire Protection Association, in addition to the standards of any authorities having jurisdiction. Failure to do so may impair the performance of these devices.



The owner is responsible for maintaining their fire protection system and devices in proper operating condition. Contact the installing contractor or sprinkler manufacturer with any questions.

Sprinkler Identification Number (SIN)

TY2524

IMPORTANT

Always refer to Technical Data Sheet TFP700 for the "INSTALLER WARNING" that provides cautions with respect to handling and installation of sprinkler systems and components. Improper handling and installation can permanently damage a sprinkler system or its components and cause the sprinkler to fail to operate in a fire situation or cause it to operate prematurely.

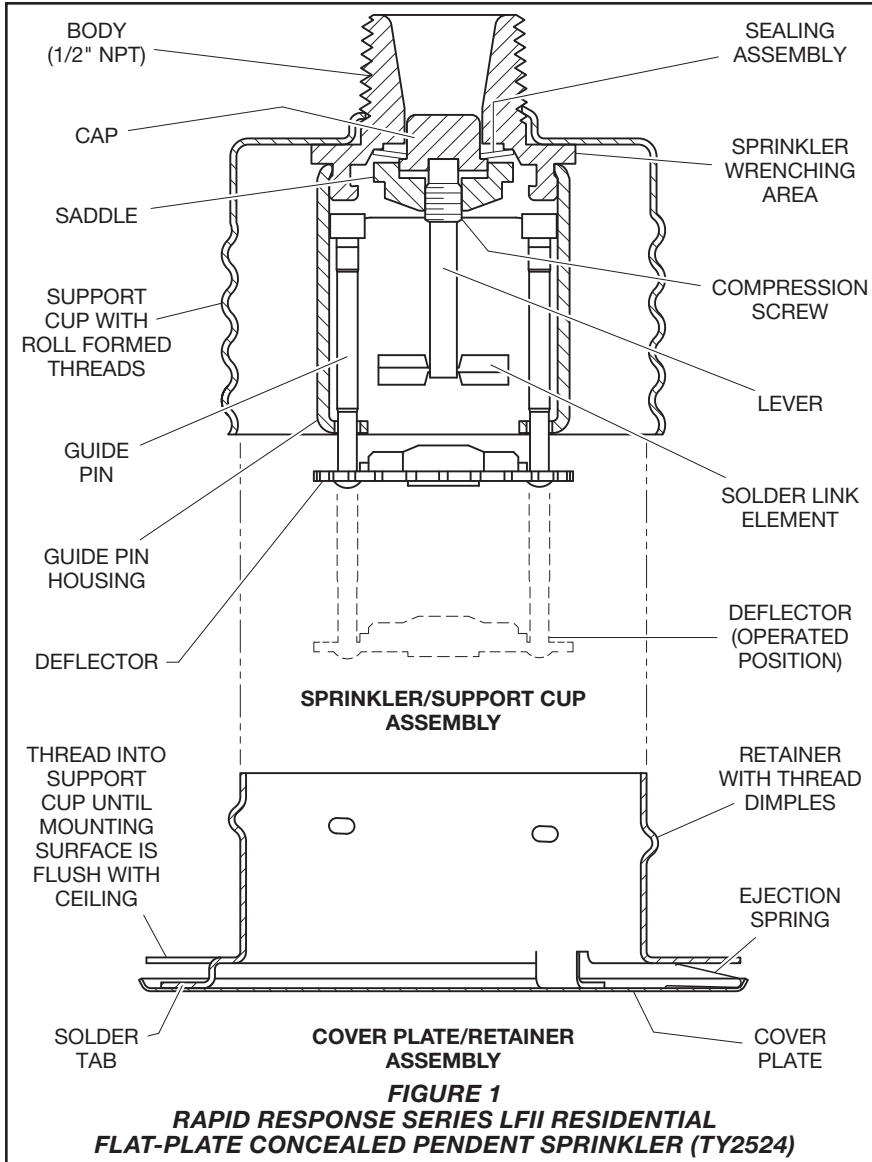

FIGURE 1
RAPID RESPONSE SERIES LFI RESIDENTIAL
FLAT-PLATE CONCEALED PENDENT SPRINKLER (TY2524)

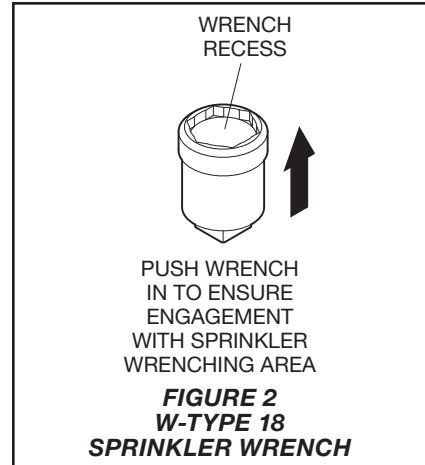

FIGURE 2
W-TYPE 18
SPRINKLER WRENCH

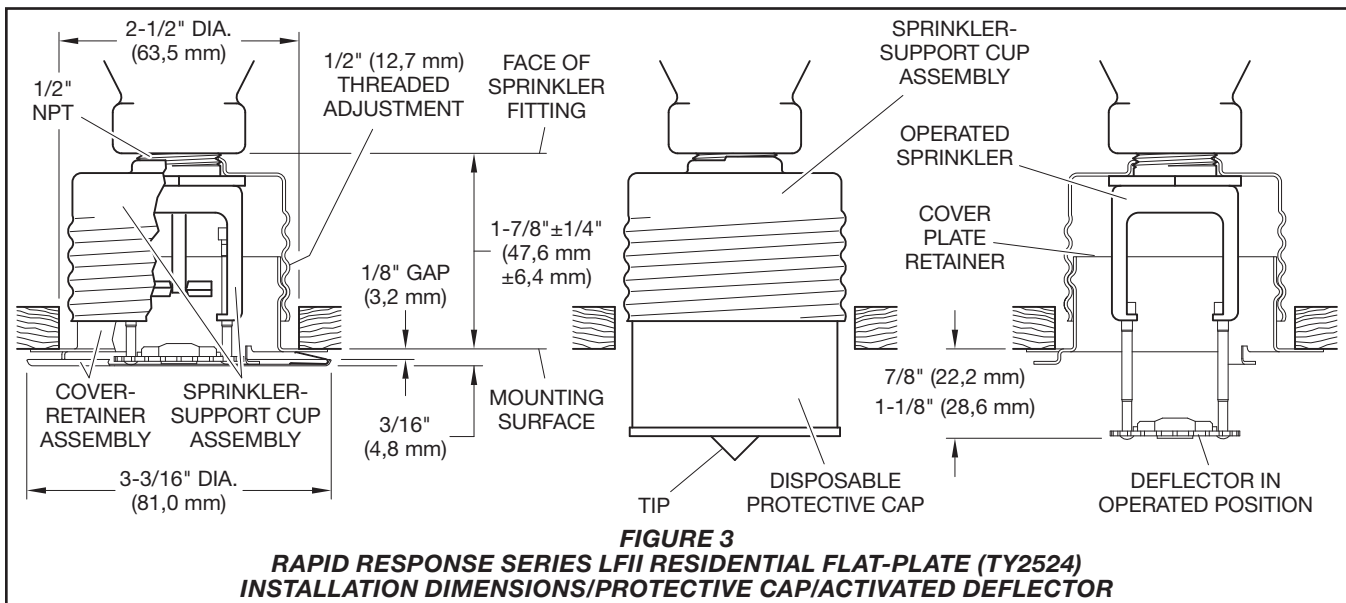

FIGURE 3
RAPID RESPONSE SERIES LFI RESIDENTIAL FLAT-PLATE (TY2524)
INSTALLATION DIMENSIONS/PROTECTIVE CAP/ACTIVATED DEFLECTOR

Technical Data

Approvals

UL and C-UL Listed

The TYCO RAPID RESPONSE Series LFII Residential Flat-Plate Concealed Pendent Sprinklers are only listed with the Series LFII Concealed Cover Plates having a factory-applied finish.

These Cover Plates and their part numbers can be found in the Ordering Procedure section at the end of this data sheet.

For details on approvals, refer to the Design Criteria section.

Maximum Working Pressure

175 psi (12,1 bar)

Discharge Coefficient

$K = 4.9 \text{ GPM/psi}^{1/2} (70,6 \text{ LPM/bar}^{1/2})$

Temperature Rating

Sprinkler: 160°F (71°C)

Cover Plate: 139°F (59°C)

Vertical Adjustment

1/2 inch (12,7 mm)

Finishes

Refer to the Ordering Procedure section.

Physical Characteristics

Cover Plate/Retainer Assembly:

Cover Plate Copper
Ejection Spring Stainless Steel
Retainer Brass

Sprinkler/Support Cup Assembly:

Body Brass
Cap Bronze
Saddle Brass
Sealing Assembly Beryllium
Nickel w/ TEFLON

Soldered Link Halves Nickel
Lever Bronze
Compression Screw Brass
Deflector Bronze
Guide Pin Housing Bronze
Guide Pins Bronze
Support Cup Steel

Operation

When exposed to heat from a fire, the Cover Plate, which is normally soldered to the Retainer at three points, falls away to expose the Sprinkler/Support Cup Assembly. At this point, the Deflector, supported by the Guide Pins, drops down to its operated position.

The Solder Link Element of the Sprinkler/Support Cup Assembly is comprised of two link halves that are soldered together with a thin layer of solder. When the rated temperature is reached, the solder melts and the two link halves separate, allowing the sprinkler to activate and flow water.

Design Criteria

The TYCO RAPID RESPONSE Series LFII Residential Flat-Plate Concealed Pendent Sprinklers (TY2524) are UL and C-UL Listed for installation in accordance with this section:

Residential Sprinkler Design Guide

When conditions exist that are outside the scope of the provided criteria, refer to the Residential Sprinkler Design Guide TFP490 for the manufacturer's recommendations that may be acceptable to the authority having jurisdiction.

System Type

Per the UL Listing, wet pipe and dry pipe systems may be utilized. Per the C-UL Listing, only wet pipe systems may be utilized.

Refer to Technical Data Sheet TFP485 about the use of Residential Sprinklers in residential dry pipe systems.

Ceiling Types

Smooth flat horizontal, or beamed, or sloped, in accordance with the 2013 Edition of NFPA 13D, 13R or 13 as applicable.

Hydraulic Design (NFPA 13D and 13R)

For systems designed to NFPA 13D or NFPA 13R, the minimum required sprinkler flow rate are given in Tables A and B as a function of temperature rating and the maximum allowable coverage areas. The sprinkler flow rate is the minimum required discharge from each of the total number of "design sprinklers" as specified in NFPA 13D or NFPA 13R. The number of "design sprinklers" specified in NFPA 13D and 13R for wet pipe systems is to be applied when designing dry pipe systems.

Hydraulic Design (NFPA 13)

For systems designed to NFPA 13, the number of design sprinklers is to be the four most hydraulically demanding sprinklers. The minimum required discharge from each of the four sprinklers is to be the greater of the following:

- The flow rates given in Tables A and B as a function of temperature rating and the maximum allowable coverage area
- A minimum discharge of 0.1 gpm/ft² over the "design area" comprised of the four most hydraulically demanding sprinklers for the actual coverage areas being protected by the four sprinklers

The number of "design sprinklers" specified in NFPA 13 for wet pipe systems is to be applied when designing dry pipe systems.

Dry Pipe System Water Delivery

When using the Series LFII Residential Flat-Plate Concealed Pendent Sprinklers (TY2524) in dry pipe sprinkler systems, the time for water delivery must not exceed 15 seconds for the most remote operating sprinkler.

Obstruction to Water Distribution

Sprinklers are to be located in accordance with the obstruction rules of NFPA 13D, 13R, and 13 as applicable for residential sprinklers as well as with the obstruction criteria described within the Technical Data Sheet TFP490.

Operational Sensitivity

Install sprinklers relative to the ceiling mounting surface as shown in Figure 3.

The Series LFII Residential Flat-Plate Concealed Pendent Sprinklers must not be used in applications where the air pressure above the ceiling is greater than that below. Down drafts through the Support Cup can delay sprinkler operation in a fire situation.

Sprinkler Spacing

The minimum spacing between sprinklers is 8 feet (2,4 m). The maximum spacing between sprinklers cannot exceed the length of the coverage area (Table A) being hydraulically calculated (e.g., a maximum of 12 feet for a 12 ft. x 12 ft. coverage area or 20 feet for a 20 ft. x 20 ft. coverage area.)

Maximum Coverage Area ^(a) Ft. x Ft. (m x m)	Maximum Spacing Ft. (m)	WET PIPE SYSTEM Minimum Flow and Residual Pressure ^(b, c)				
		Ordinary Temp Rating 160°F (71°C)		Deflector to Ceiling	Installation Type	Minimum Spacing Ft. (m)
		Flow GPM (L/min)	Pressure PSI (bar)			
12 x 12 (3,7 x 3,7)	12 (3,7)	13 (49,2)	7.0 (0,48)	Smooth Ceilings 7/8 to 1-1/8 inches. Beamed Ceilings per NFPA 13D 13R, or 13 Installed in beam 7/8 to 1-1/8 inches below bottom of beam	Concealed	8 (2,4)
14 x 14 (4,3 x 4,3)	14 (4,3)	13 (49,2)	7.0 (0,48)			
16 x 16 (4,9 x 4,9)	16 (4,9)	13 (49,2)	7.0 (0,48)			
18 x 18 (5,5 x 5,5)	18 (5,5)	17 (64,3)	12.0 (0,83)			
20 x 20 (6,1 x 6,1)	20 (6,1)	20 (75,7)	16.7 (1,15)			

- (a) For coverage area dimensions less than or between those indicated, use the minimum required flow for the next highest coverage area for which Hydraulic Design section under the Design Criteria are stated.
- (b) The Minimum Flow requirement is based on minimum flow in GPM (LPM) from each sprinkler. The associated residual pressures are calculated using the nominal K-factor. Refer to "Hydraulic Design" in the Design Criteria section for details.
- (c) For NFPA 13 residential applications, the greater of 0.1 gpm/ft.² over the design area or the flow in accordance with the criteria in this table must be used.

TABLE A
WET PIPE SYSTEM
SERIES LFII RESIDENTIAL FLAT-PLATE CONCEALED PENDENT SPRINKLER (TY2524)
NFPA 13D, 13R, AND 13 HYDRAULIC DESIGN CRITERIA

Maximum Coverage Area ^(a) Ft. x Ft. (m x m)	Maximum Spacing Ft. (m)	DRY PIPE SYSTEM Minimum Flow and Residual Pressure ^(b)				
		Ordinary Temp Rating 160°F (71°C)		Deflector to Ceiling	Installation Type	Minimum Spacing Ft. (m)
		Flow GPM (L/min)	Pressure PSI (bar)			
12 x 12 (3,7 x 3,7)	12 (3,7)	15 (56,8)	9.4 (0,65)	Smooth Ceilings 7/8 to 1-1/8 inches. Beamed Ceilings per NFPA 13D 13R, or 13 Installed in beam 7/8 to 1-1/8 inches below bottom of beam	Concealed	8 (2,4)
14 x 14 (4,3 x 4,3)	14 (4,3)	15 (56,8)	9.4 (0,65)			
16 x 16 (4,9 x 4,9)	16 (4,9)	16 (60,6)	10,7 (0,74)			
18 x 18 (5,5 x 5,5)	18 (5,5)	17 (64,3)	12.0 (0,83)			
20 x 20 (6,1 x 6,1)	20 (6,1)	21 (79,5)	18,4 (1,27)			

- (a) For coverage area dimensions less than or between those indicated, use the minimum required flow for the next highest coverage area for which Hydraulic Design section under the Design Criteria are stated.
- (b) The Minimum Flow requirement is based on minimum flow in GPM (LPM) from each sprinkler. The associated residual pressures are calculated using the nominal K-factor. Refer to "Hydraulic Design" in the Design Criteria section for details.
- (c) For NFPA 13 residential applications, the greater of 0.1 gpm/ft.² over the design area or the flow in accordance with the criteria in this table must be used.

TABLE B
DRY PIPE SYSTEM
SERIES LFII RESIDENTIAL FLAT-PLATE CONCEALED PENDENT SPRINKLER (TY2524)
NFPA 13D, 13R, AND 13 HYDRAULIC DESIGN CRITERIA

Installation

The TYCO RAPID RESPONSE Series LFII Residential Flat-Plate Concealed Pendent Sprinklers must be installed in accordance with this section:

General Instructions

Damage to the Solder Link Element during installation can be avoided by handling the sprinkler by the Support Cup only; that is, do not apply pressure to the Solder Link Element (Figure 1).

A leak-tight 1/2 inch NPT sprinkler joint should be obtained by applying a minimum-to-maximum torque of 7 to 14 ft.-lbs. (9,5 to 19,0 Nm). Higher levels of torque can distort the sprinkler inlet with consequent leakage or impairment of the sprinkler.

Do not attempt to compensate for insufficient adjustment in the Cover Plate/Retainer Assembly by under- or over-tightening the sprinkler. Re-adjust the position of the sprinkler fitting to suit.

Step 1. Install pendent sprinklers in the pendent position, with the centerline of the sprinkler perpendicular to the mounting surface.

Step 2. Remove the Protective Cap.

Step 3. With pipe-thread sealant applied to the pipe threads, and using the W-Type 18 Wrench shown in Figure 2, install and tighten the Sprinkler/Support Cup Assembly into the fitting. The W-Type 18 Wrench accepts a 1/2 inch ratchet drive.

Step 4. Replace the Protective Cap by pushing it upwards until it bottoms out against the Support Cup. The Protective Cap helps prevent damage to the Deflector and Guide Pins during ceiling installation and/or during application of the finish coating of the ceiling.

NOTICE

As long as the protective Cap remains in place, the system is considered "Out Of Service".

Step 5. After the ceiling has been completed with the 2-1/2 inch (63 mm) diameter hole and in preparation for installing the Cover Plate/Retainer Assembly, remove and discard the Protective Cap, and verify that the Deflector moves up and down freely.

If the sprinkler has been damaged and the deflector does not move up and down freely, replace the entire sprinkler assembly. Do not attempt to modify or repair a damaged sprinkler.

Step 6. Screw on the Cover Plate/Retainer Assembly until its flange contacts the ceiling. Do not continue to screw on the Cover Plate/Retainer Assembly such that it lifts a ceiling panel out of its normal position.

If the Cover Plate/Retainer Assembly cannot be engaged with the Mounting Cup or the Cover Plate/Retainer Assembly cannot be engaged sufficiently to contact the ceiling, the Sprinkler Fitting must be repositioned.

Care and Maintenance

The TYCO RAPID RESPONSE Series LFII Residential Flat-Plate Concealed Pendent Sprinkler (TY2524) must be maintained and serviced in accordance with this section:

Before closing a fire protection system main control valve for maintenance work on the fire protection system that it controls, obtain permission to shut down the affected fire protection system from the proper authorities and notify all personnel who may be affected by this action.

Absence of a Cover Plate may delay the sprinkler operation in a fire situation.

The owner must assure that the sprinklers are not used for hanging any objects and that the sprinklers are only cleaned by means of gently dusting with a feather duster; otherwise, non-operation in the event of a fire or inadvertent operation may result.

When properly installed, there is a nominal 1/8 inch (3,2 mm) air gap between the lip of the Cover Plate and the ceiling, as shown in Figure 3. This air gap is necessary for proper operation of the sprinkler by allowing heat flow from a fire to pass below and above the Cover Plate to help assure appropriate release of the Cover Plate in a fire situation. If the ceiling needs repainting after sprinkler installation, exercise care to ensure that the new paint does not seal off any of the air gap. Failure to do so may impair sprinkler operation.

Factory painted Cover Plates must not be repainted. They should be replaced, if necessary, by factory painted units. Non-factory applied paint may adversely delay or prevent sprinkler operation in the event of a fire.

Do not pull the Cover Plate relative to the Retainer. Separation may result.

Sprinklers which are found to be leaking or exhibiting visible signs of corrosion must be replaced.

Automatic sprinklers must never be painted, plated, coated, or otherwise altered after leaving the factory. Modified or overheated sprinklers must be replaced.

Care must be exercised to avoid damage to the sprinklers - before, during, and after installation. Sprinklers damaged by dropping, striking, wrench twist/slippage, or the like, must be replaced.

The owner is responsible for the inspection, testing, and maintenance of their fire protection system and devices in compliance with this document, as well as with the applicable standards of the National Fire Protection Association (e.g., NFPA 25), in addition to the standards of any other authorities having jurisdiction. Contact the installing contractor or sprinkler manufacturer regarding any questions.

Automatic sprinkler systems are recommended to be inspected, tested, and maintained by a qualified Inspection Service in accordance with local requirements and/or national codes.

Limited Warranty

For warranty terms and conditions, visit
www.tyco-fire.com.

Ordering Procedure

Contact your local distributor for availability. When placing an order, indicate the full product description and Part Number (P/N).

Sprinkler/Support Cup Assembly

Specify: Series LFII (TY2524), K = 4.9 (70,6), Residential Flat-Plate Concealed Pendent Sprinkler without Cover Plate/Retainer Assembly, P/N 51-114-1-160

Cover Plate/Retainer Assembly

Specify: Series LFII (TY2524), K = 4.9 (70,6), Residential Flat-Plate Concealed Pendent Sprinkler Cover Plate/Retainer Assembly with (specify) finish, P/N (specify):

Ivory (RAL 1015) P/N 56-202-0-135
Beige (RAL 1001) P/N 56-202-2-135
Pure White (b) (RAL 9010) P/N 56-202-3-135
Signal White (a) (RAL 9003) P/N 56-202-4-135
Grey White (RAL 9002) P/N 56-202-5-135
Brown (RAL 8028) P/N 56-202-6-135
Black (RAL 9005) P/N 56-202-7-135
Brushed Brass P/N 56-202-8-135
Brushed Chrome P/N 56-202-9-135
Custom Paint P/N 56-202-X-135

(a) Previously known as Bright White.
(b) Eastern Hemisphere sales only.

Note: All Custom Cover Plates are painted using Sherwin Williams Interior Latex Paint. Contact TYCO Customer Service with any questions related to custom orders.

Sprinkler Wrench

Specify: W-Type 18 Sprinkler Wrench, P/N 56-000-1-265