

Model CC1 — 2.8 K-factor Combustible Concealed Space Sprinklers Specific Application, Upright

General Description

The Model CC1 Combustible Concealed Sprinklers are fast response, upright, specific application sprinklers designed to provide protection of light hazard combustible, as well as non-combustible, concealed spaces requiring sprinkler protection. The CC1 Sprinklers comply with the criterion for the protection of combustible concealed spaces as described in NFPA 13.

The Model CC1 Sprinklers can in some cases allow for the use of BlazeMaster CPVC piping within concealed spaces requiring automatic sprinkler protection. At one time, the listing of CPVC piping for fire protection systems did not allow the use of CPVC piping in combustible concealed spaces requiring automatic sprinkler protection. With the extensive full scale fire testing of the Model CC1 Combustible Concealed Space Sprinklers, performed at UL, BlazeMaster CPVC may now be used in the specified combustible concealed spaces requiring automatic sprinkler protection, when installed in accordance with this technical data sheet.

The effectiveness of the Model CC1 Sprinklers, in the combustible concealed spaces investigated, was clearly evident during the full scale fire testing for this product. Concealed spaces between floors, as well as low pitch attics are inherently shallow. Standard spray sprinklers, by design,

IMPORTANT

Always refer to Technical Data Sheet TFP700 for the "INSTALLER WARNING" that provides cautions with respect to handling and installation of sprinkler systems and components. Improper handling and installation can permanently damage a sprinkler system or its components and cause the sprinkler to fail to operate in a fire situation or cause it to operate prematurely.

have an umbrella like spray pattern that poses a difficult challenge when trying to achieve effective coverage within a shallow space. The Model CC1 Combustible Concealed Space Sprinklers have addressed this difficult fire challenge.

NOTICE

The Model CC1 Combustible Concealed Sprinklers described herein must be installed and maintained in compliance with this document, as well as with the applicable standards of the National Fire Protection Association, in addition to the standards of any other authorities having jurisdiction. Failure to do so may impair the performance of these devices.

The owner is responsible for maintaining their fire protection system and devices in proper operating condition. Contact the installing contractor or product manufacturer with any questions

Sprinkler Identification Numbers (SINs)

TY1189 - Upright, 2.8K
TY1189 is a redesignation for C1189.

Technical Data

Approvals
UL Listed.

(Listings and approvals only apply to the service conditions indicated in the Design Criteria sections.)

Maximum Working Pressure
175 psi (12,1 bar)

Pipe Thread Connection
1/2 inch NPT or ISO 7-R 3/4



Discharge Coefficient
K = 2.8 gpm/psi^{1/2}
(40,3 lpm/bar^{1/2})

Temperature Rating
175°F (79°C)

Finish
Natural Brass

Physical Characteristics

Frame.....	Brass
Button.....	Bronze
Sealing Assembly.....	Stainless Steel w/TEFLON
Bulb.....	Glass (3 mm)
Compression Screw.....	Brass
Deflector.....	Bronze

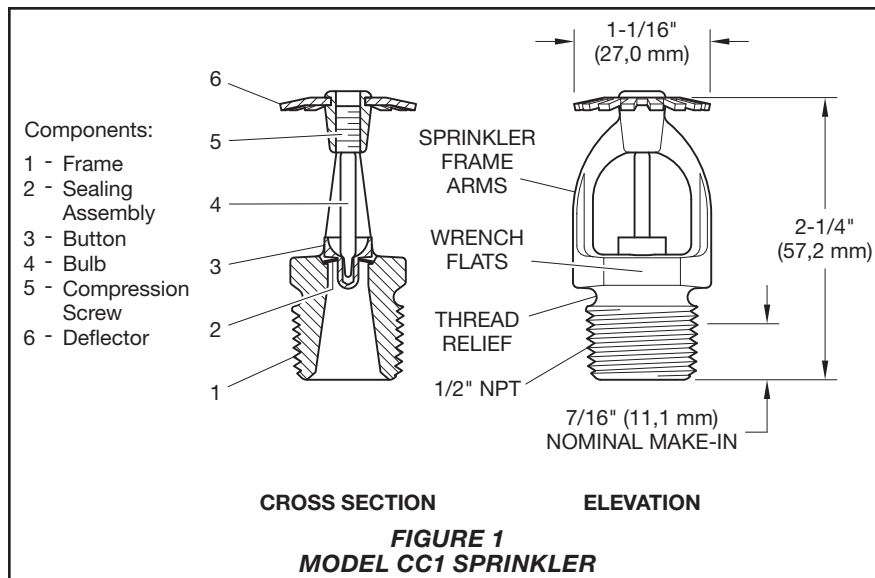

Operation

The glass bulb contains a fluid that expands when exposed to heat. When the rated temperature is reached, the fluid expands sufficiently to shatter the glass bulb allowing the sprinkler to activate and flow water.

Design Criteria

CPVC Pipe (Fig. 2 & 3)

Area of Use:

Horizontal (slope not exceeding 2 in 12) combustible concealed spaces of:

- Wood truss construction or bar joist construction (Fig. 2)
- Non-combustible insulation filled solid wood or composite wood joist construction (Fig. 3)

NOTE: In order to be considered "non-combustible insulation filled solid wood or composite wood joist construction", the insulation (including insulation provided with a combustible vapor barrier), must completely fill the pockets between the joists to the bottom of the joists, and the insulation must be secured in place with metal wire netting. The metal wire netting is intended to hold the insulation in place should the insulation become wetted by the operation of the CC1 Sprinklers in the event of a fire.

Concealed Space Area:

The area of the concealed space is not limited; however, for both Fig. 2 and Fig. 3, where CPVC pipe is being utilized, draft-curtains or full height walls must be provided at 1000 ft² (93

m²) areas. This draft curtain shall be at least 1/3 the depth of the concealed space or 8 inches (200 mm), whichever is greater, and be constructed using a material which will not allow heat to escape through or above the draft curtain.

Concealed Space Size

The depth of the concealed space is 36 inches (915 mm) maximum to 12 inches (305 mm) minimum.

System Type

Light hazard, wet pipe system

Minimum Distance Between CC1 Sprinklers

6 feet (3,1 m). Minimum spacing does not apply to any additional sprinklers required for protection of BlazeMaster CPVC that is offset over an obstruction.

Maximum Distance Between CC1 Sprinklers

10 feet (3,1 m).

Maximum Coverage Area

100 ft² (9,3 m²)

Deflector Position

1-1/2 to 4 inches (40 to 100 mm) below upper deck for wood truss construction or bar joist construction (Fig. 2).

1-1/2 to 2 inches (40 to 50 mm) below solid wood or composite wood joists (Fig. 3).

Minimum Distance Away from Trusses

4-1/2 inches (114 mm)

Remote Area

The remote area is 1000 ft² (93 m²).

The remote area does not include any additional sprinklers required for protection of BlazeMaster CPVC that is offset over an obstruction.

Required Density

0.10 gpm/ft² (4,1 mm/min)

Minimum Operating Pressure

10 psi (0,7 bar)

Obstructions

All obstruction criteria per NFPA for standard spray sprinklers apply (Ref. Figure 8), unless modified by this technical data sheet.

UL Listed Use of BlazeMaster CPVC Piping with Model CC1 Sprinklers

Only BlazeMaster CPVC product may be used in concealed spaces requiring automatic sprinklers, when used in conjunction with Model CC1 Sprinklers. In order to use the BlazeMaster CPVC product for wood truss or bar joist construction, the horizontal run of pipe must be a maximum of 6 inches (150 mm) above the ceiling or non-combustible ceiling insulation, or 1/3 the depth of concealed space (as measured from the top surface of the ceiling to the bottom of the deck above), whichever is smaller (Fig. 2). For insulation filled solid wood or composite wood joist construction, the horizontal run of pipe must be a maximum of 6 inches (150 mm) above ceiling or non-combustible ceiling insulation, or 1/3 the depth of concealed space (as measured from the top surface of the ceiling to the bottom surface of the joist insulation above), whichever is smaller (Fig. 3). The CPVC piping can then be used to supply the Model CC1 Sprinklers, as well as the sprinklers below the ceiling. Unless modified by this Technical Data Sheet, all other guidelines of the "BlazeMaster — Installation Instructions & Technical Manual" must be met. When using 1 inch (DN25) or larger pipe, a hanger must be located at the truss nearest a sprig for purposes of restraint. If using 3/4 inch (DN19) piping, all sprigs over 12 inches (305 mm) must be laterally braced using methods described in the NFPA standards.

Where the CPVC must be offset up and over an obstruction and the pipe exceeds the allowed horizontal positioning requirements specified above as well as shown in Figure 2 and 3, additional Model CC1 Sprinklers are to be installed as shown in Figure 2 and 3 to protect the BlazeMaster CPVC product.

A minimum lateral distance of 18 inches (460 mm) must be maintained between the CPVC pipe and heat pumps, fan motors, and heat lamps.

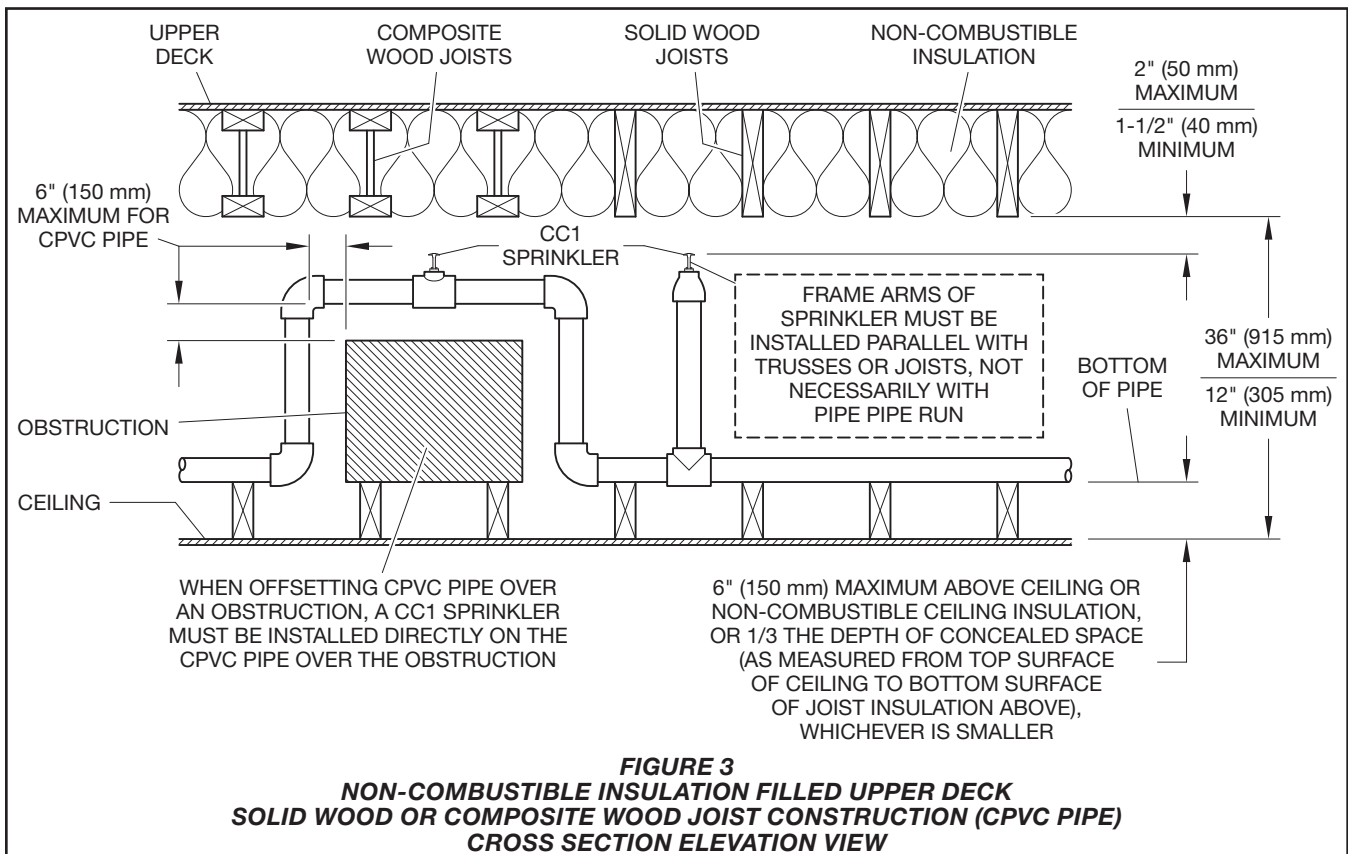
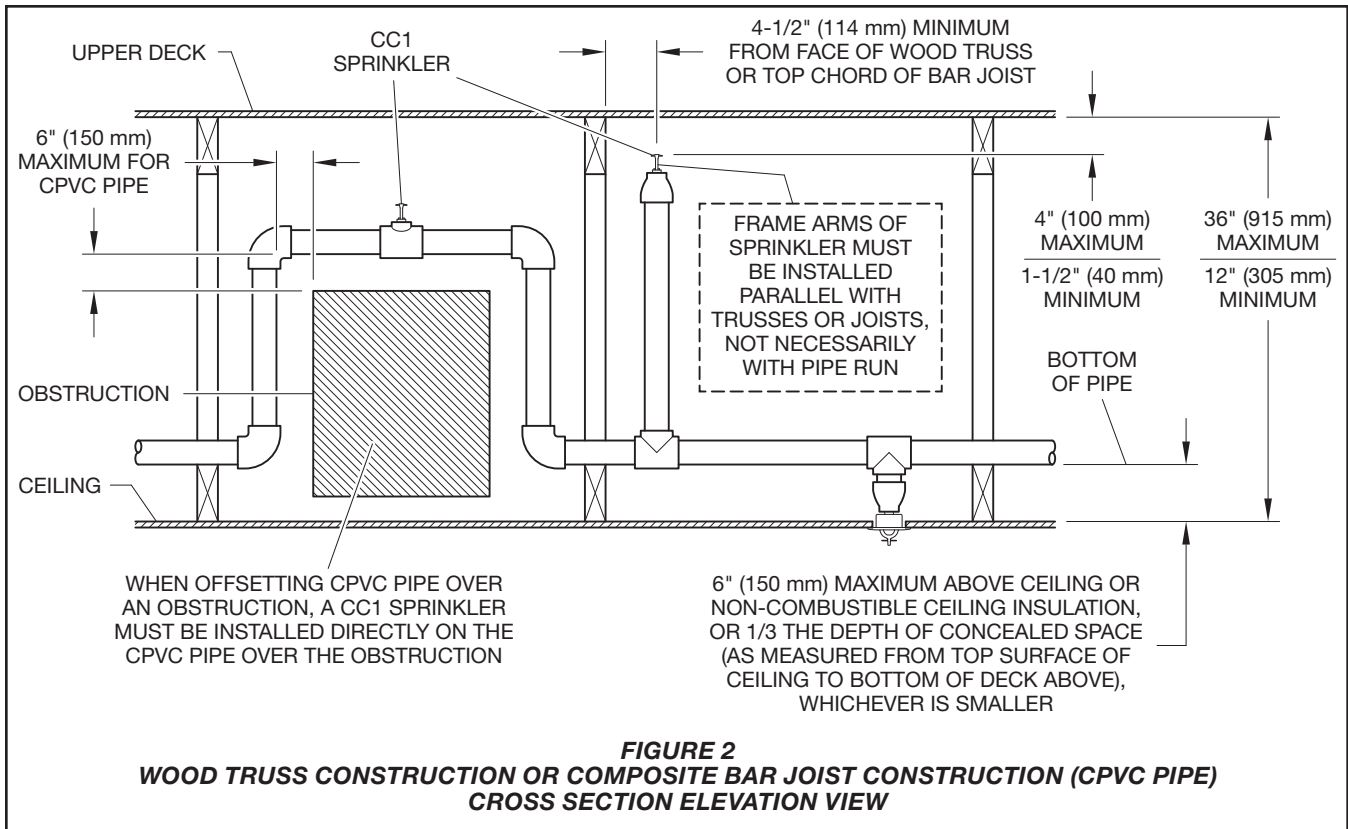

Design Criteria

Steel Pipe (Fig. 4, 5, & 6)

Area of Use:

Horizontal (slope not exceeding 2 in 12) combustible concealed spaces of:

- wood truss construction or bar joist construction (Fig. 4)
- solid wood joist construction (Fig. 5) where the upper deck and ceiling joists may have a maximum depth of 12 inches (300 mm) and typical on center joist spacing of minimum 16 inches (400 mm)
- non-combustible insulation filled solid wood joist or wood composite joist construction (Fig. 6)

NOTE: In order to be considered "non-combustible insulation filled solid wood joist or composite wood joist construction", the insulation (including insulation provided with a combustible vapor barrier), must completely fill the pockets between the joists to the bottom of the joists, and the insulation must be secured in place with metal wire netting. The metal wire netting is intended to hold the insulation in place should the insulation become wetted by the operation of the CC1 Sprinklers in the event of a fire.

Concealed Space Area

The area of the concealed space is not limited; however:

- for wood truss construction or concealed spaces of non-combustible bar joist construction (Fig. 4) draft-curtains or full height walls must be provided at 1000 ft² (93 m²) areas. This draft curtain shall be at least 1/3 the depth of the concealed space or 8 inches (200 mm), whichever is greater, and be constructed using a material which will not allow heat to escape through or above the draft curtain.
- for solid wood joist construction (Fig. 5), blocking must be provided in each upper deck and ceiling joist channel at a maximum 32 feet (9,75 m) intervals. This blocking shall be installed to the full depth of the joists and be installed so as to not allow heat to escape through or above the blocking. The blocking must be constructed using a non-combustible material or the joist construction material.

Solid wall construction or draft curtains must protrude below the joist a minimum of 6 inches (150 mm) or 1/3 the space, whichever is smallest and run laterally with the joist spaced

at 25 feet (7,6 m) width maximum to limit the area to a maximum of 1000 ft² (93 m²). The draft curtain may be constructed of 1/4 inch (6,4 mm) plywood to prevent heat from escaping beyond the area.

- For non-combustible insulation filled solid wood joist or composite wood joist construction (Fig. 6), the requirement for draft curtains or blocking does not apply.

Concealed Space Size

The minimum and maximum concealed space depth is as follows:

For wood truss construction or concealed spaces of non-combustible bar joist construction (Fig.4) the depth of the concealed space is 36 inches (915 mm) maximum to 12 inches (305 mm) minimum.

For solid wood joist construction (Fig. 5) or for non-combustible insulation filled solid wood or composite wood joist construction (Fig. 6), the maximum depth of the concealed space is 54 inches (1372 mm) from bottom of upper deck to top of ceiling, and the minimum depth is 6 inches (150 mm) from the bottom of the upper deck joists to the top of the ceiling joists.

System Type

Light hazard, wet pipe system

Minimum Distance Between CC1 Sprinklers

6 feet (1,8 m)

Maximum Distance Between CC1 Sprinklers

10 feet (3,1 m)

Maximum Coverage Area

100 ft² (9,3 m²)

Deflector Position

1-1/2 to 4 inches (40 to 100 mm) below upper deck for wood truss construction or concealed spaces of non-combustible bar joist construction (Fig. 4)

1-1/2 to 2 inches (40 to 50 mm) below solid wood joists (Fig. 5)

1-1/2 to 2 inches (40 to 50 mm) below non-combustible insulation filled solid wood joists or composite wood joists (Fig. 6)

Remote Area

The remote area for wood truss construction or bar joist construction (Fig. 4) or solid wood joist construction (Fig. 5) is 1000 ft² (93 m²).

The remote area for non-combustible insulation filled solid wood joist or wood composite joist construction (Fig. 6) is to be calculated per the requirements of NFPA 13.

Required Density

0.10 gpm/ft² (4,1 mm/min)

Minimum Operating Pressure

10 psi (0,7 bar)

Obstructions

All obstruction criteria per NFPA for standard spray sprinklers apply (Ref. Figure 8), unless modified by this technical data sheet.

Installation

The Model CC1 Sprinklers must be installed in accordance with this section.

General Instructions

The CC1 Sprinklers are to be installed upright and with their frame arms (ref. Figure 2, 3, 4, 5, or 6 as applicable) parallel with the wood trusses, top chord of the bar joist, or wood joists, as opposed to being necessarily parallel with the pipe.

Do not install any bulb type sprinkler if the bulb is cracked or there is a loss of liquid from the bulb. With the sprinkler held horizontally, a small air bubble should be present. The diameter of the air bubble is approximately 1/16 inch (1,6 mm) for the 175°F (79°C) temperature rating.

A leak tight 1/2 inch NPT sprinkler joint should be obtained with a torque of 7 to 14 ft.-lbs. (9,5 to 19,0 Nm). Higher levels of torque may distort the sprinkler inlet with consequent leakage or impairment of the sprinkler.

The Model CC1 Sprinklers must only be installed in the upright position with the deflector parallel to the upper deck. With pipe thread sealant applied to the pipe threads, use only the W-Type 20 (End B) Sprinkler Wrench (Figure 7) for installation of the Model CC1 Sprinklers by applying the wrench to the sprinkler wrench flats only.

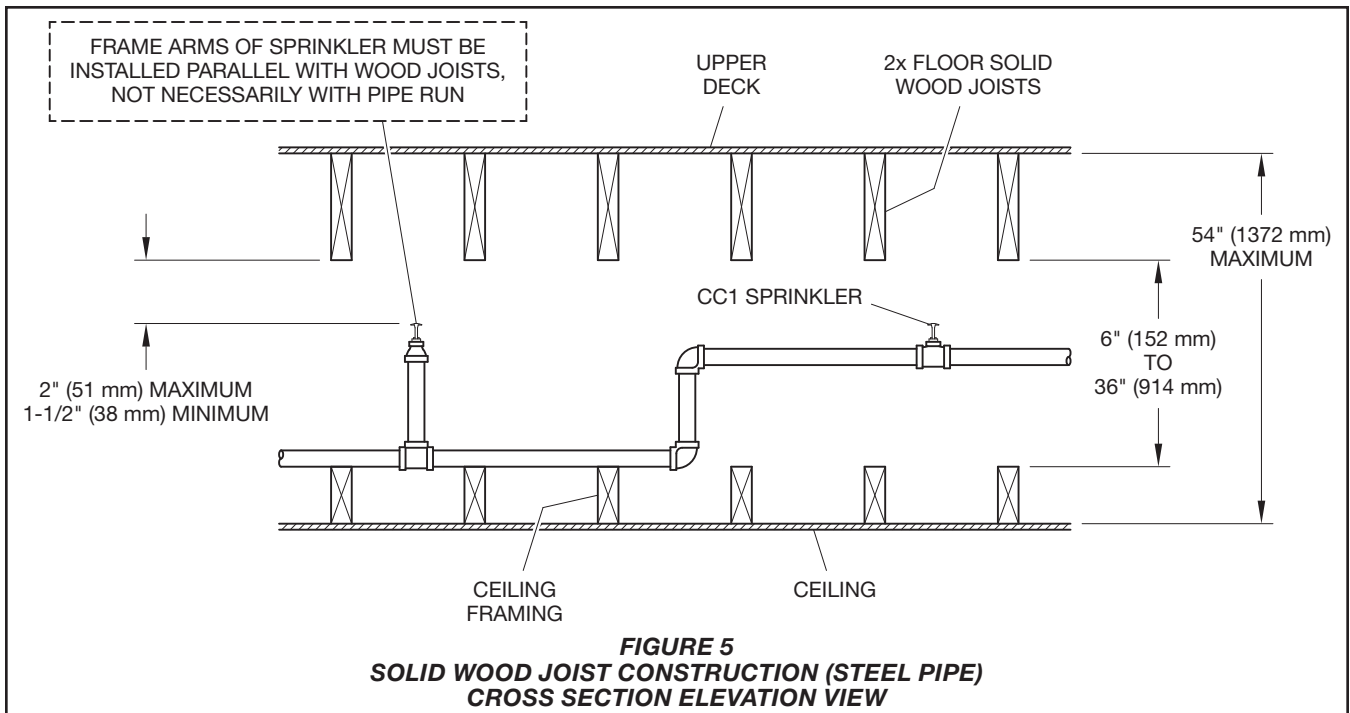
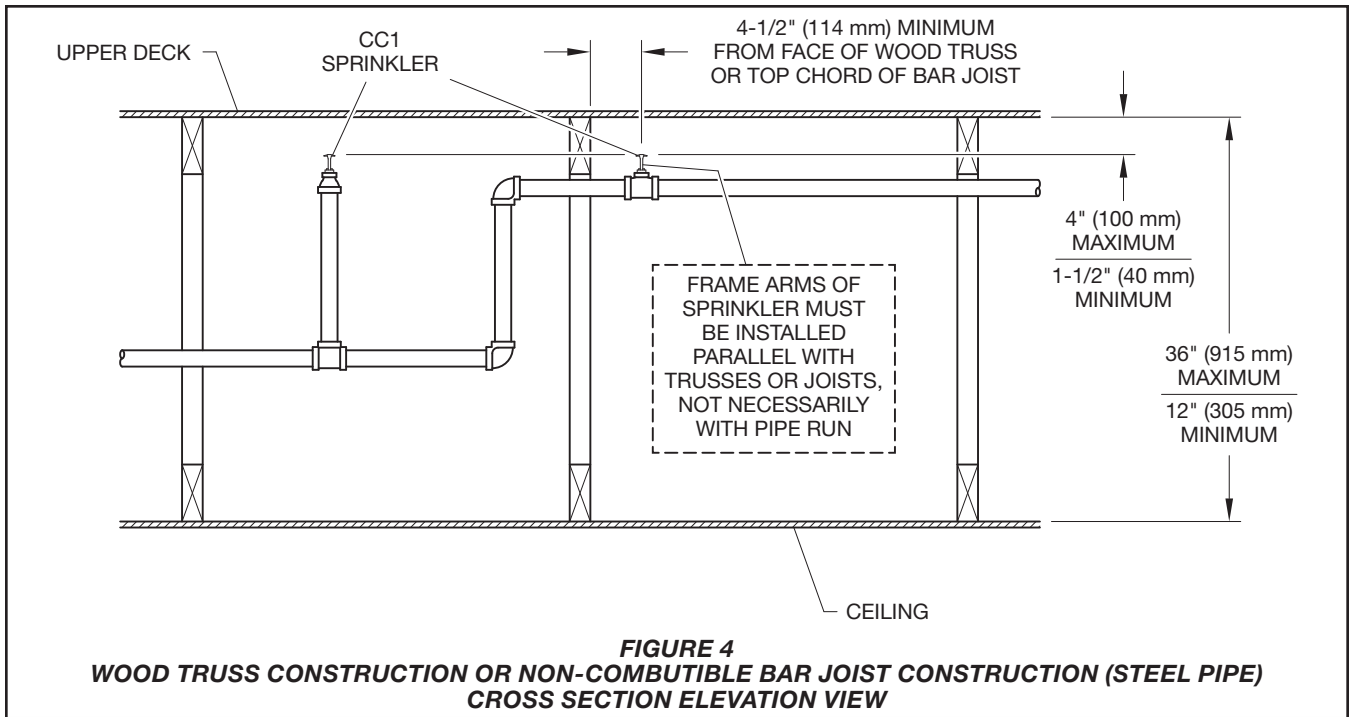

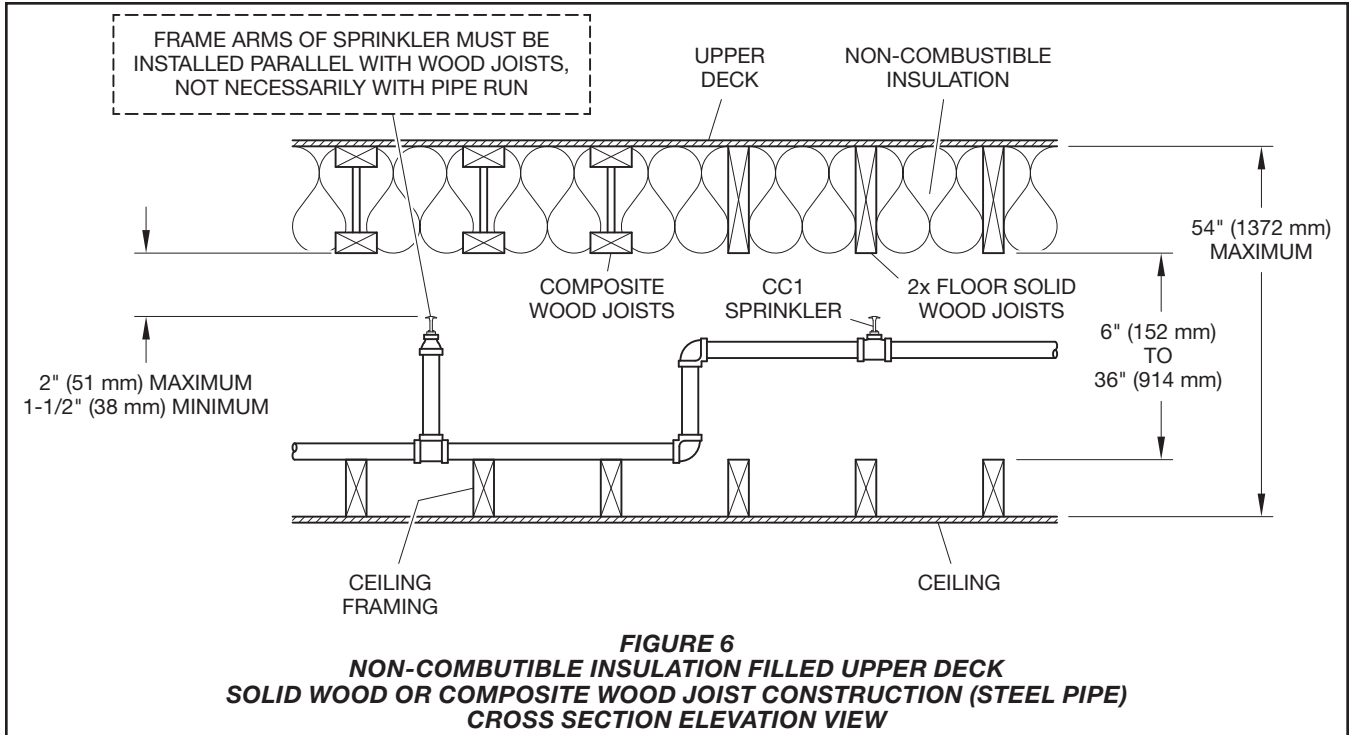

Care and Maintenance

The Model CC1 Sprinklers must be maintained and serviced in accordance with this section:

Before closing a fire protection system main control valve for maintenance work on the fire protection system that it controls, permission to shut down the affected fire protection systems must be obtained from the proper authorities and all personnel who may be affected by this action must be notified.

Sprinklers that are found to be leaking or exhibiting visible signs of corrosion must be replaced.

Automatic sprinklers must never be painted, plated, coated, or otherwise altered after leaving the factory. Modified sprinklers must be replaced. Sprinklers that have been exposed to corrosive products of combustion, but have not operated, should be replaced if they cannot be completely cleaned by wiping the sprinkler with a cloth or by brushing it with a soft bristle brush.

Care must be exercised to avoid damage to the sprinklers before, during, and after installation. Sprinklers damaged by dropping, striking, wrench twist/slippage, or the like, must be replaced. Also, replace any sprinkler that has a cracked bulb or that has lost liquid from its bulb. (Ref. Installation Section).

The owner is responsible for the inspection, testing, and maintenance of their fire protection system and devices in compliance with this document, as well as with the applicable standards of the National Fire Protection Association (e.g., NFPA 25), in addition to the standards of any other authorities having jurisdiction. Contact the installing contractor or product manufacturer with any questions.

It is recommended that automatic sprinkler systems be inspected, tested, and maintained by a qualified Inspection Service in accordance with local requirements and/or national codes.

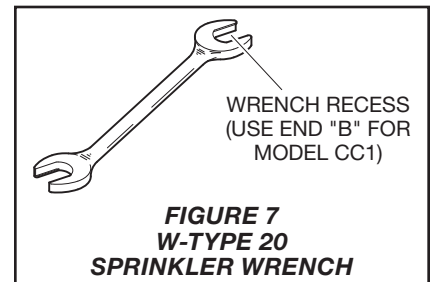

Limited Warranty

For warranty terms and conditions, visit www.tyco-fire.com.

Ordering Procedure

Contact your local distributor for availability. When placing an order, indicate the full product name and Part Number (P/N).

Sprinkler Assembly with NPT Thread Connections

Specify: TY1189, 2.8 K-factor, Model CC1, 175°F (79°C), Upright, Specific Application, Combustible Concealed Space Sprinkler, P/N 50-300-1-175

Sprinkler Wrench

Specify: W-Type 20 Sprinkler Wrench, P/N 56-000-1-106

